

The Exergy of Crude Oil Mixtures and Petroleum Fractions: Calculation and Application *

Ricardo RIVERO, Consuelo RENDON and Leodegario MONROY
Exergy Group, Instituto Mexicano del Petróleo
07730 Mexico City, Mexico
E-mail: rrivero@imp.mx

Abstract

The methodology used for calculating the physical exergy and the chemical exergy of mixtures of crude oils and their fractions is presented in this paper, using computer programs coupled with the AspenPlus simulation code. First, the procedure for the detailed characterization of a crude oil mixture is described, based on the results of experimental assays. After that, the steps required to determine the reference conditions needed for the calculation of the physical exergy are presented, and the sequence by which these values are retrieved from a simulation run is explained, in order to be used in a fortran computer program. Finally, from the mixture characterization, the procedure for determining the chemical exergy of each component (identified components and pseudo-components) of the mixture is presented, in order to add it to the physical exergy to obtain the total exergy of the mixture stream. The methodology is illustrated with a mixture of Mexican Maya and Isthmus crude oils, and its application to the analysis of a crude oil combined distillation unit is presented in this paper.

Key words: exergy analysis, crude oil, petroleum fractions, thermodynamic properties

1. Introduction

Depending on their amount of light components, sulfur and metals, crude oils are considered as heavy crude oils or light crude oils (see TABLE I). The crude oil called "Maya" is a very heavy crude oil (with a sulfur content of 3.69 weight (wt) %) and the crude oil called "Isthmus" is a light crude oil (with a sulfur content of 1.43 wt%). Maya (heavy) crude oil is more difficult to refine than Isthmus (light) crude oil; unfortunately Mexican oil reserves are much more important in Maya crude oil. Because of this the crude oil refining industry in Mexico as well as in other countries is increasing the amount of heavy crude oil in the feed.

In the conventional refining schemes existing several years ago in Mexico the crude oil processed was a mixture of 68.7 wt% (70 vol%) of Isthmus crude oil and 31.3 wt% (30 vol%) of Maya crude oil. These schemes are being modified in order to process a mixture of 48.5/51.5 wt% (50/50 vol%) of Isthmus and Maya crude

oils in the refineries in Mexico and a refinery in Texas has been modified to process a mixture with more than 81.3 wt% (80 vol%) of Maya crude oil.

TABLE I. Typical Crude Oil Properties.

| Property | Isthmus | Maya |
|--------------------------------|---------|--------|
| Average Molecular Weight | 207.60 | 295.48 |
| Sulfur Content (wt%) | 1.43 | 3.69 |
| Net Heating Value (kJ/kg) | 42611 | 41671 |
| Reid Vapor Pressure (bar) | 0.51 | 0.42 |
| Watson Characterization Factor | 11.26 | 11.20 |
| Carbon Content (wt%) | 0.00 | 5.51 |
| Reid Vap. Pres-ASTM (bar) | 0.38 | 0.16 |
| Mercaptan Content (wt%) | 0.00 | 0.27 |
| Nickel Content (wt%) | 0.00 | 0.01 |
| Vanadium Content (wt%) | 0.01 | 0.06 |
| API Degrees Standard | 33.82 | 23.05 |

* This paper was presented at the ECOS'98 Conference in Nancy, June 8-10, 1998

The thermodynamic value of the different crude oils and of the products obtained from them, has thus become crucial in the revamping process of the refineries, and it is necessary to have a measure to rigorously quantify this quality.

Exergy is a thermodynamic property that is a measure of the quality of energy contained in a substance and of its departure in temperature, pressure and composition from the environment conditions. Consequently it allows consideration in an integral way energetic, economic and ecological aspects in analyzing industrial processes (Rivero 1993).

2. Crude Oil Mixture Characterization

Crude oils are mixtures of many chemically identified components (hydrocarbons) and many other components called pseudo-components for which the chemical identity is difficult and sometimes impractical to determine. Instead of the chemical composition of pseudo-components a series of bulk properties are determined, from which the thermodynamic properties can be estimated.

For the characterization of crude oils, there are several sources of information, the best of which are the experimental assays. In this procedure the crude oil is separated by heating, identifying the light components which are sequentially produced at different temperatures (IMP 1997).

The information obtained from an experimental assay can be introduced into the data banks of computer simulation programs like AspenPlus* (AspenTech 1996 a). The data banks of AspenPlus contain the distillation curves and the API gravity of several crude oils including the Maya and Isthmus crude oils, as well as the following properties for them: aniline point, flash point, freezing point, mercaptans content, naphthenes content, nickel content, paraffins content, vapor pressure, sulfur content and vanadium content.

The information contained in the data banks is very valuable though limited but it can be completed with real experimental data. When the experimental assays are available, all light components experimentally determined can be considered, as well as hydrogen sulfide and water. These constitute the "identified components" of the crude oil mixture.

There are several characterization methods available in AspenPlus, one of which is called REL 9, which generates the "pseudo-components" based on the API method with some modifications introduced by Aspen.

The following bulk properties experimentally determined can be introduced to AspenPlus for conducting the characterization: API degree, molecular weight, sulfur content, pour point, basic nitrogen content, total nitrogen content, vapor pressure, vanadium content, nickel content, iron content, ramsbottom carbon content and lights composition.

Additionally, the following property curves as a function of the distilled volume % can be introduced for the characterization: distillation curve, API degree curve, kinematic viscosity curve, sulfur curve, mercaptans curve, pour point curve, basic nitrogen curve, total nitrogen curve, ramsbottom carbon curve, aromatics curve, paraffins curve, aniline point curve, freezing point curve and molecular weight curve.

The result of the mixture characterization is mainly the detailed chemical composition of the identified components and the pseudo-components of the crude oil mixture, from which the thermodynamic properties can now be calculated.

3. Calculation Procedure

3.1 Physical exergy

Physical exergy of a stream of matter can be defined as the maximum work (useful energy) that can be obtained from it in taking it to physical equilibrium (of temperature and pressure) with the environment (Rivero 1993).

$$Ex_f = (H - H_0) - T_0(S - S_0) \quad (1)$$

Where the enthalpy and the entropy of the substance have to be evaluated at its temperature and pressure conditions (T, P) and at the temperature and pressure of the environment (T₀, P₀). Enthalpy and entropy at the stream and reference conditions are evaluated for the same chemical composition (X) of the stream of matter and considering all mixing effects if the stream contains several components. This evaluation has to be conducted using the most suitable method for predicting thermodynamic properties for the substance at its temperature and pressure conditions.

There are several thermodynamic option sets available in AspenPlus for evaluating the properties of petroleum mixtures (AspenTech 1996 b).

* AspenPlus is a trademark from Aspen Technology Inc.

The BK10 option set uses the Braun K-10 K-value correlations. The correlations were developed from the K10 charts for both real components and oil fractions. The real components include 70 hydrocarbons and light gases. The oil fractions cover boiling ranges 450-700 K. Proprietary methods were developed by Aspen to cover heavier oil fractions (AspenTech 1996 b). This option set is suited for vacuum and low pressure applications (up to several atm). For calculating the liquid and vapor enthalpy of petroleum mixtures the BK10 option set uses the Lee-Kesler (1975) model, vapor entropy is calculated with the ideal gas model and liquid entropy is calculated with the Braun K-10 model for liquid fugacity coefficients.

Another option set available for petroleum mixtures is the Grayson option set, which uses the Grayson-Streed (1963) correlation for reference state fugacity coefficients and the Scatchard-Hildebrand (1962) model for activity coefficients. The Redlich-Kwong (1979) equation of state, is used for vapor phase entropy, the Lee-Kesler (1975) equation of state for liquid and vapor enthalpy, and Grayson-Streed and extended Scatchard-Hildebrand models for liquid entropy. This option set is recommended for systems containing hydrogen and was developed for systems containing hydrocarbons and light gases, such as carbon dioxide and hydrogen sulfide (AspenTech 1996 b).

Other option sets available in AspenPlus for petroleum mixtures are the Chao-Seader (1961) option set and the petroleum-tuned equations of state, such as Peng-Robinson (1976) and Redlich-Kwong-Soave (1972).

As mentioned, the BK10 option set is generally used for applications at vacuum or low pressures (up to several atm). Chao-Seader and Grayson can be used at higher pressures. Grayson has the widest ranges of applicability (up to several tens of atm). For hydrogen-rich systems, Grayson is recommended. These option sets are less suited for high-pressure applications in refineries (above about 50 atm). Petroleum-tuned equation-of-state option sets are preferred for high pressures.

No matter the thermodynamic option set used in the simulation of a process with AspenPlus, enthalpy and entropy at reference conditions (T_0 , P_0) are evaluated with two fortran subroutines, USRH XO and USRS XO (Rivero, 1998); these subroutines are linked to the main simulation code and execute an internal Aspen subroutine called FLASH which calculates the equilibrium at the dead state reference conditions established.

The values of the enthalpy and entropy at the stream conditions (P , T) and at the reference conditions (T_0 , P_0) are then retrieved from the results file of the simulation run using the AspenPlus Toolkit. Physical exergy is calculated inside the fortran code described later.

3.2. Chemical exergy

Chemical exergy of a stream of matter can be defined as the maximum work (useful energy) that can be obtained from it in taking it to chemical equilibrium (of composition) with the environment (Rivero 1993).

$$Ex_q = (H - H_0) - T_0(S - S_0) \quad (2)$$

where the enthalpy and the entropy have to be evaluated for the chemical composition of the substance (X) and for the chemical composition (X_0) of the environment products obtained from the substance by reacting with environment components; enthalpy and entropy for the stream and environment compositions are evaluated for the same temperature and pressure, normally the environment conditions (T_0 , P_0).

For many identified substances, the standard chemical exergy (i.e. at T_0 and P_0) can be found in the literature, however for the pseudo-components the chemical exergy can be determined from heuristic empirical expressions as a function of the elementary composition and the heating value of each pseudo-component (Szargut et al. 1988).

The standard specific chemical exergy (e.g. in kJ/kg) of each pseudo-component is calculated with the following modified expression:

$$Ex_{q,i} = NH V_i \beta_i + \sum z_j Ex_{q,j} \quad (3)$$

where z_j are the mass fractions of metals, Fe, Ni, V, and water in the pseudo-component and $Ex_{q,j}$ are their corresponding specific standard chemical exergies, obtained from the standard chemical exergy values of the Szargut (Szargut et al. 1988) reference model. NHV_j is the net heating value of the pseudo-component j and β_j is the chemical exergy correction factor as a function of its C, H₂, O₂, S, and N₂, mass fractions:

$$\beta = 1.0401 + 0.1728 \frac{z_{H_2}}{z_C} + 0.0432 \frac{z_{O_2}}{z_C} + 0.2169 \frac{z_S}{z_C} \left(1 - 2.0628 \frac{z_{H_2}}{z_C} \right) + 0.0428 \frac{z_{N_2}}{z_C} \quad (4)$$

The standard molar chemical exergy (e.g. in kJ/kmol) of the crude oil stream can be calculated from the standard molar chemical exergies of all identified components (obtained from the Szargut tables, 1988) and pseudo-components

(converting their standard specific chemical ex- energies to a molar basis) and the mol fractions of

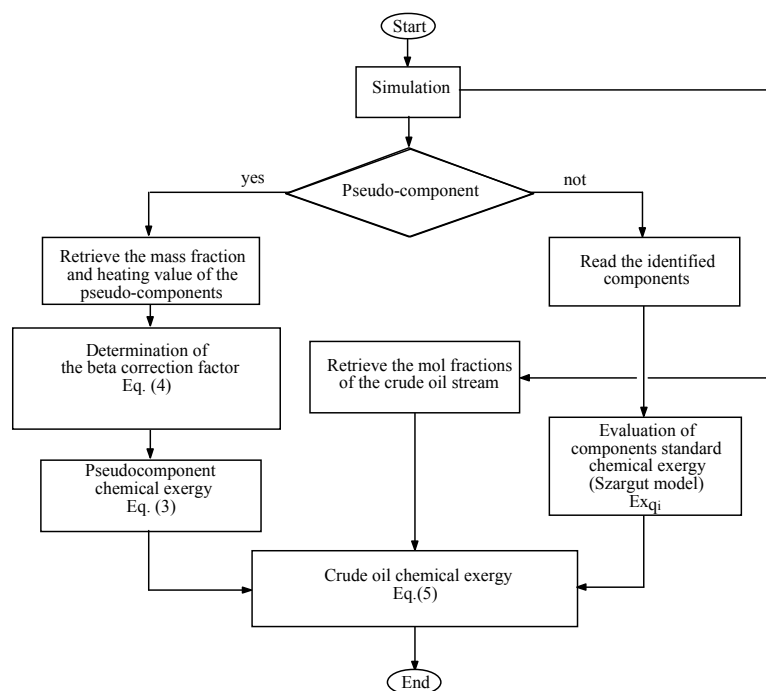

Figure 1. Calculation procedure of chemical exergy.

all identified components and pseudo-components.

$$Ex_q = \sum x_i Ex_{qi} + R T_0 \sum x_i \ln x_i \gamma_i \quad (5)$$

The second term in the right hand side of Equation (5) is called the compositional exergy (Rivero 1993).

The calculation procedure is shown in Figure 1.

3.3 Total exergy

The total exergy of a stream of matter is simply the sum of physical exergy and chemical exergy, i.e. it is defined as the maximum work (useful energy) that can be obtained from it in taking it to complete equilibrium (of temperature, pressure and composition) with the environment (Rivero 1993):

$$Ex = Ex_f + Ex_q \quad (6)$$

The total exergy is obtained with a fortran program that reads the chemical exergy of the identified components and the pseudo-components from a data bank and retrieves the simulation results from the summary file using the AspenPlus toolkit (i.e. H, H₀, S, S₀ and mol fractions) which are used for evaluating the

physical exergy. The calculation procedure is shown in Figure 2.

4. Exergy of a Crude Oil Mixture

The total exergy of a 51.5/48.5 wt% mixture of Maya and Isthmus crude oils to be processed in a combined distillation unit was evaluated for temperatures going from 100 to 1000 °C

Figure 2. Calculation procedure of total exergy.

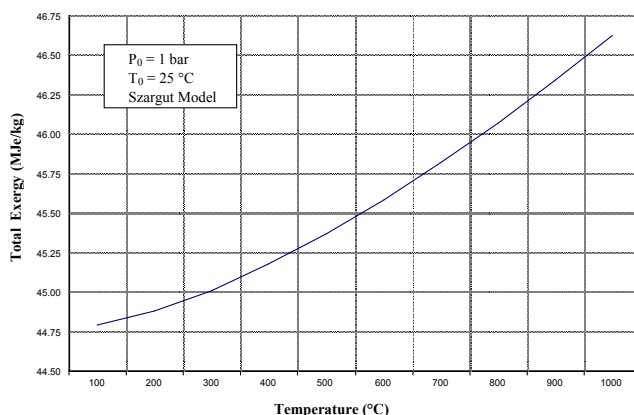
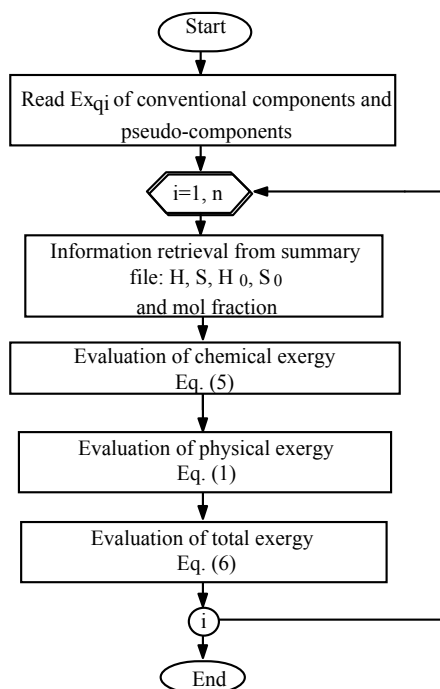

Figure 3. Total exergy of a mixture of Isthmus/Maya crude oils (48.5/51.5 wt%) at 1 bar.

at 1 bar using initially the BK10 option set and the AspenPlus data banks for Isthmus and Maya Crude Oils.

The results of this evaluation are presented in Figure 3 where it can be observed that the physical exergy contribution to the total exergy of the mixture is minimum compared to the chemical exergy. The physical exergy of the mixture represents only 4 % of the total exergy at 1000 °C.

For this crude oil mixture and using the experimental data for its characterization (IMP 1997) the chemical exergy correction factor β of the 38 different pseudo-components obtained from the characterization vary from 1.068 to 1.075. Thus in some applications, the net heating value of the pseudo-components

could be used as a first approximation of their chemical exergy.

In order to evaluate the influence of the activity coefficient on the chemical exergy of the mixture, another calculation was made using the Grayson thermodynamic option set.

TABLE II shows the results of the compositional exergy considering the activity coefficients evaluated with the Scatchard-Hildebrand model, compared with the results obtained considering all activity coefficients equal to 1.0. As can be noted, the influence of the activity coefficient on the compositional exergy is not very high, about 6.5 % of error, which in terms of the chemical exergy becomes 0.0052 % of error. However it is important to mention that in a crude oil distillation unit the chemical exergy can be seen as a

transit exergy which is not consumed in the separation process but a compositional exergy gain is obtained in the separation of the crude oil mixture. If the crude oil mixture is not split into pseudo-components, the net heating value of the bulk mixture and its elementary bulk composition could also be used for an estimation of the chemical exergy. The chemical exergy correction factor for the mixture is 1.074, giving a chemical exergy of 11036.71 MJ/kmol which can be compared with the value presented in TABLE II, i.e. an error of 0.69 %.

Coming back to the AspenPlus data banks for Isthmus and Maya crude oils, the chemical exergy as a function of the mixture composition is shown in Figure 4. The difference in exergy

between both crude oils is about 1.077 MJ/kg.

5. Application to a Crude Oil Combined Distillation Unit

The combined distillation unit is one of the most important plants of a crude oil refinery, because it produces basic refining products such as naphtha, jet fuel, kerosene, diesel and gas oil. Important exergy consumption and losses in refineries are produced in the combined distillation unit due to its degree of complexity (Rivero 1988, Rivero et al. 1989).

The main performance parameters involved in the exergy analysis of complex systems are the Irreversible Exergy Losses (Irr) and the Effluent

TABLE II. Compositional and Chemical Exergies of a Crude Oil Mixture.

| | Scatchard-Hildebrand activity coefficients model | all activity coefficients equal to 1.0 | % error |
|---|--|--|---------|
| compositional exergy (MJ/kmol) $R T_0 \sum x_i \ln x_i \gamma_i$ | -8.765 | -9.333 | 6.47 |
| chemical exergy (MJ/kmol) | 10960.505 | 10959.937 | 0.0052 |

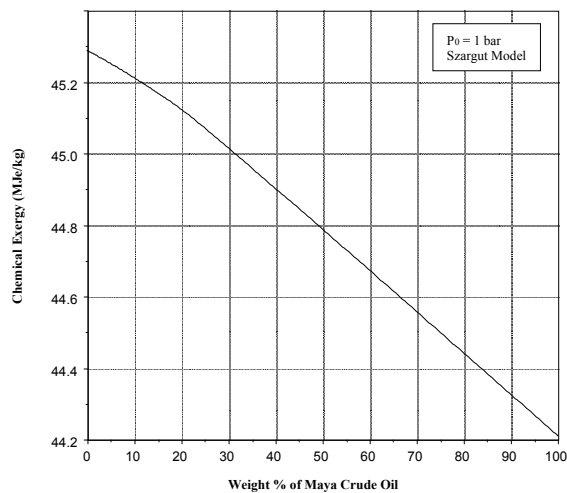

Figure 4. Chemical exergy of a mixture of Isthmus/Maya crude oils.

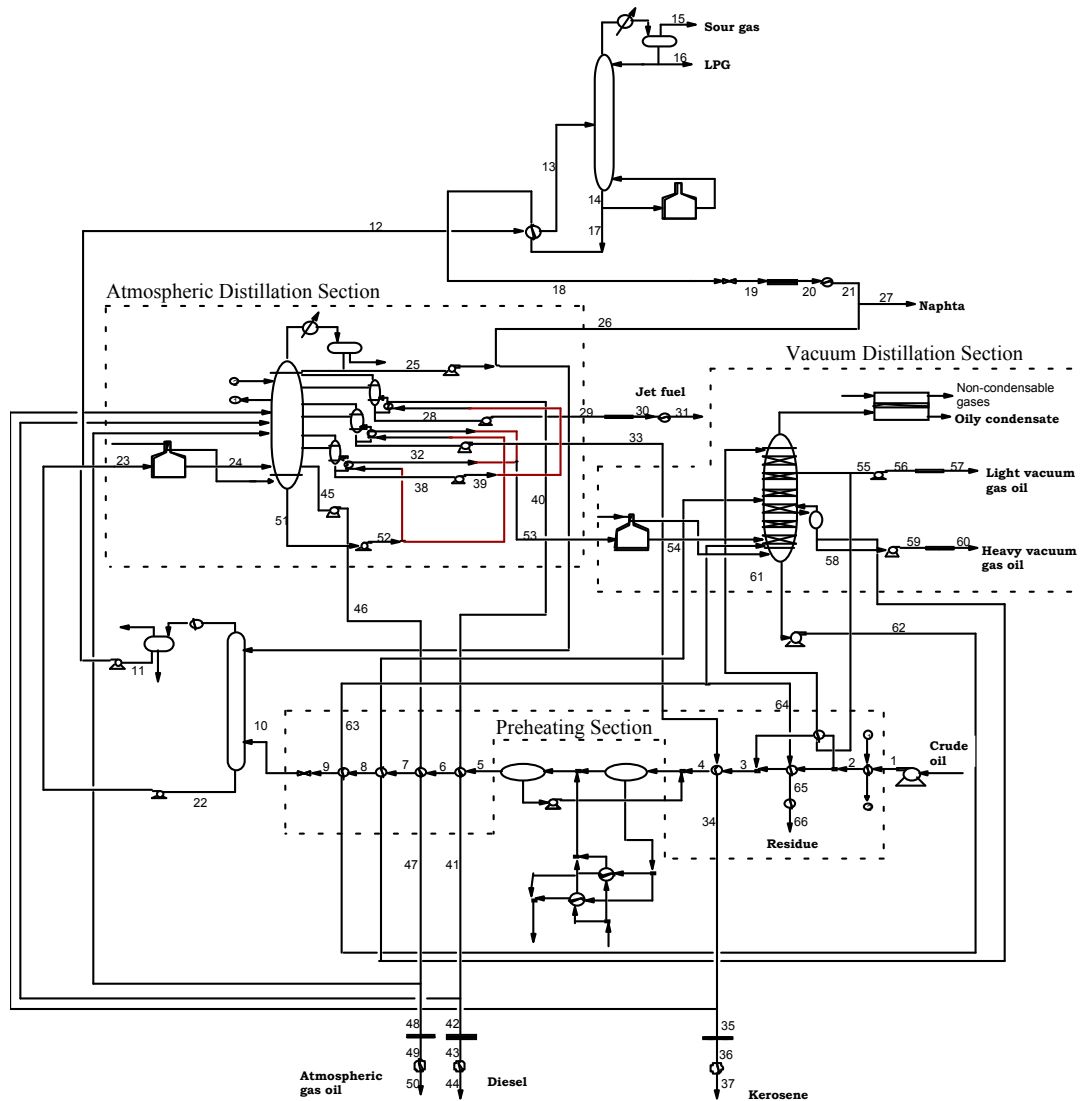

Figure 5. Crude oil combined distillation unit.

Exergy Losses (Efl), which are considered separately in order to explicitly use the ecological implications of the exergy concept. Also the Effectiveness, defined as the ratio of the net exergy produced to the net exergy supplied (ϵ) is calculated for each block, section and the whole unit; this parameter is the rational way of knowing how well a block or equipment is performing its function, i.e. the desired effect. Another important parameter is the Improvement Potential (Pot) of each block, which combines the previous parameters in order to have a measure of how much and how easily a block could be theoretically improved for optimization purposes (Rivero 1988):

$$\text{Pot} = \text{Irr} (1 - \epsilon) + \text{Efl} \quad (7)$$

In the combined distillation unit, the crude oil mixture is separated into several products

which are sent to other refinery units for further processing. For the exergy analysis this unit was divided into 70 blocks which receive, produce or are interconnected by 230 exergy streams. Figure 5 shows a simplified flowsheet of the combined distillation unit, indicating three of its most important sections (Rivero 1998).

The exergy analysis of the unit indicates that 87% of the total exergy losses are irreversible exergy losses in the blocks, whereas the remaining 13% are effluent exergy losses (flue gases and cooling water).

The atmospheric distillation section of the unit represents 69% of the exergy losses, the vacuum distillation section 7% and the crude oil preheating section 5%. The remaining sections represent together 13%. The overall process effectiveness of the unit is as low as 3.6%.

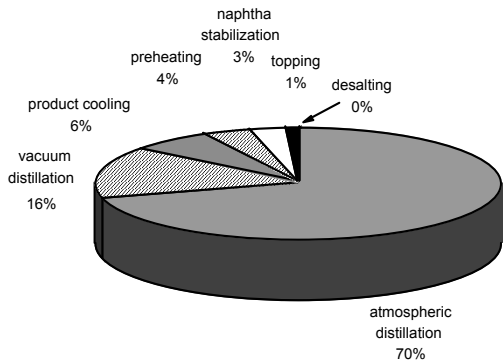

Figure 6. Distribution of improvement potentials.

From the process effectiveness point of view, the atmospheric distillation section is 18% effective, whereas the process effectiveness of the vacuum distillation section is 5% and that of the preheating section is 76%.

Figure 6 shows the distribution of the sum of improvement potentials of the blocks composing each section of the combined distillation unit. It is important to note that the preheating section became the fourth in importance as compared to the distribution of total exergy losses due to its relatively high (76%) process effectiveness. The sum of improvement potentials represents 60% of the total exergy losses of the unit.

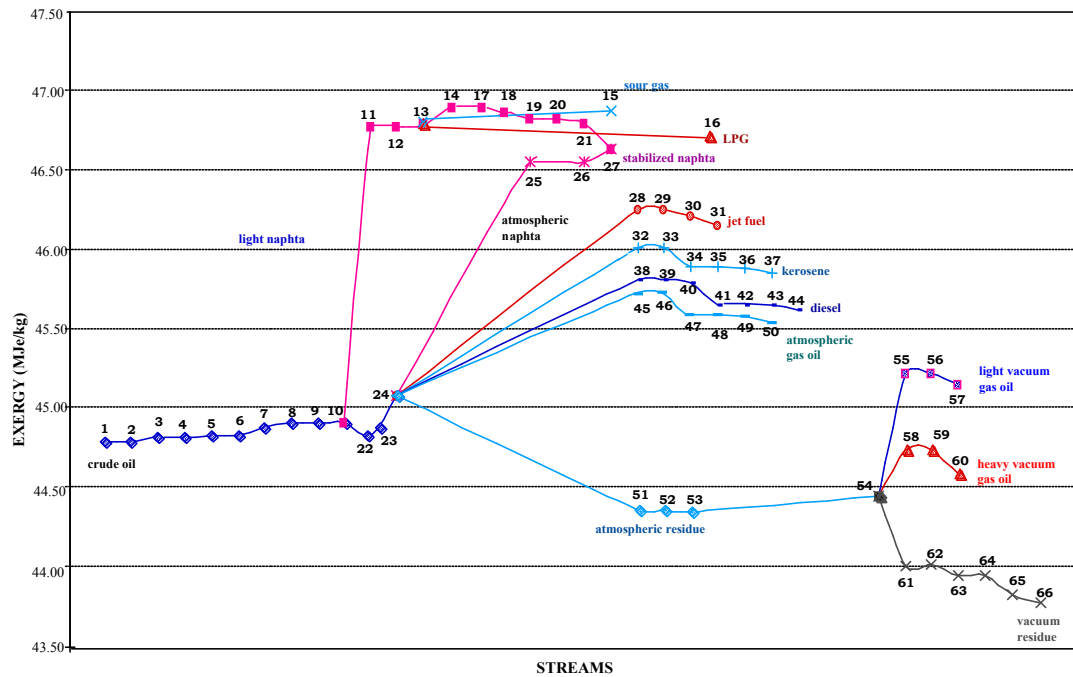

Figure 7. Specific exergy of process streams in a crude oil combined distillation unit.

Important improvement proposals for this unit have been made and are being evaluated in order to increase its effectiveness and reduce its relative exergy losses. These concern mainly modifications in the process flowsheet and the implementation of several energy systems such as diabatic distillation and heat pumps.

An interesting picture of the unit is obtained with the specific exergy profile of the process streams presented in Figure 7. The small numbers in the diagram correspond to the numbers in the flowsheet of Figure 5.

As shown in Figure 7, the thermodynamic value of the petroleum fractions obtained in the combined distillation unit can be clearly quantified by their specific exergy.

6. Conclusions

Exergy is a property that permits measurement in a quantitative manner of the thermodynamic quality of a substance, hence the importance of the infrastructure developed for its rigorous determination using computer programs linked to a process simulation code.

Detailed exergy analyses of complex systems can be conducted with that computing software.

Also, the difference existing between the Maya (lower specific exergy) and Isthmus (higher specific exergy) crude oils, as well as of the products obtained from a mixture of them, has been determined. This information is the

basis for the exergoeconomic analysis and optimization of refinery units.

Acknowledgments

This work was conducted in the frame of a research project supported by the Gerencia de Investigación y Desarrollo Tecnológico (GIDT) of Pemex-Refinación, under the coordination of Mr. Roberto Del Río (Rivero 1998). The authors wish to express their gratitude to Professors Le Goff, Moran and Tsatsaronis for their comments on the first draft of this paper.

Nomenclature

| | |
|---------------|-----------------------------------|
| Efl | effluent exergy losses |
| Ex | exergy |
| H | enthalpy |
| Irr | irreversible exergy losses |
| n | number of streams |
| NHV | net heating value |
| Pot | improvement potential |
| R | gas constant |
| S | entropy |
| T | temperature |
| x | mol fraction |
| X | composition |
| z | mass fraction |
| Greek symbols | |
| β | chemical exergy correction factor |
| γ | activity coefficient |
| ε | effectiveness |

Subscripts

| | |
|---|------------|
| f | physical |
| i | component |
| j | component |
| q | chemical |
| 0 | dead state |

References

AspenTech 1996a, *AspenPlus Release 9.3. User Guide, Volume 1*, Aspen Technology, Inc. Cambridge.

AspenTech 1996b, *AspenPlus Reference Manual, Volume 2, Release 9.3, Physical Property Methods and Models*, Aspen Technology, Inc. Cambridge.

Chao, K.C.; Seader, J.D., 1961, "A General Correlation of Vapor-Liquid Equilibria in Hydrocarbon Mixtures", *AIChE Journal*, Vol.7, pp.598-

Grayson, H.G.; Streed, C.W., 1963, *Paper 20-PO7, 6th World Petroleum Conference*, Frankfurt, June.

Hildebrand, J.H.; Scott, R.L., 1962, *Regular Solutions*, Prentice-Hall, Englewood Cliffs, N.J.,

IMP, 1997, "Procesamiento con Máxima Proporción de Crudo Maya. Evaluación de Mezclas de Crudos Maya/Ligero" Informe Técnico de Avance, Proyecto E0B-8221, Instituto Mexicano del Petróleo, México.

Lee, B.I.; Kesler, M.G., 1975, *AIChE Journal*, Vol. 21, pp. 510-

Peng, D.Y.; Robinson, D.B., 1976, "A New Two-Constant Equation-of-State", *Ind. Eng. Chem. Fundamentals*, Vol. 15, pp. 59-64.

Redlich, O.; Kwong, J.N.S., 1979, "On the Thermodynamics of Solutions V. An Equation-of-State. Fugacities of Gaseous Solutions", *Chem. Rev.*, Vol. 44, pp. 223-244.

Rivero, R., 1988, coordinador técnico. Optimización de las Instalaciones Existentes en la Refinería de Tula, Hidalgo, Utilizando el Método de Exergía. Reporte Final del Proyecto E-2277, Tomos I a IX. Grupo de Exergía - Inst. Mex. del Petróleo. México, 713 pp.

Rivero, R., 1993, "Tridimensional Exergy Diagram", in *Energy Systems and Ecology, Vol. 1, J. Szargut, Z. Kolenda, G. Tsatsaronis & A. Ziebig*, editors, Polish Ministry of National Education - American Society of Mechanical Engineers, Cracow, pp. 305-312.

Rivero, R., 1998, Investigador en Jefe, "Optimización Exérgica de un Esquema Completo de Procesamiento de Refinación. Segunda Etapa: Análisis Exérgico de la Unidad de Destilación Combinada", Informe E0A-7442-2-1, GIDT - Pemex-Refinación / Grupo de Exergía - Instituto Mexicano del Petróleo, 51 pp.

Rivero, R., González, G., García, V., Pulido, R., Escárcega, C., 1989, Exergy Analysis of a Crude Oil Atmospheric Distillation Unit. in: *Thermodynamic Analysis and Improvement of Energy Systems* ISBN: 0-08-037516-2. R.X. Cai & M.J. Moran, editors. International Academy Publishers - Pergamon Press. Beijing, pp. 506-511.

Soave, G., 1972, "Equilibrium Constants for a Modified Redlich-Kwong Equation-of-state", *Chemical Engineering Science*, Vol. 27, pp. 1196-1203.

Szargut, J.; Morris, D.R.; Steward, F.R., 1988, *Exergy Analysis of Thermal, Chemical and Metallurgical Processes*, ISBN 0-89116-574-6, Hemisphere Publishing Corporation, New York