

## History and State-of-the-Art of Fuel Fired Zero Emission Power Cycles §

Kirsten Foy  
Dublin Institute of Technology, Ireland  
E-mail: kirsten.foy@dit.ie

Evgeny Yantovski\*  
Independent Researcher, Elsass-Str. 58, D52068 Aachen, Germany  
E-mail: iksvotnay@aol.com

### Abstract

In March 2005 the world's first zero emission power plant, created by Clean Energy Systems (CES), began producing power in Kimberlina, California.

This paper presents the history of zero emission plants (also called oxyfired, oxycombustion or oxyfuel plants) from their initial conception to the present state-of-the-art, focusing particularly on the development of cycles incorporating oxygen ion transport membranes. Among others the AZEP, CES, COOPERATE, Graz, Matiant, Milano, ZEMPES, ZEITMOP and ZENG cycles are presented. The development of ion transport membrane reactors is described. The authors conclude that zero emission plants are on the verge of becoming a multibillion euro industry.

*Keywords: Zero emission, oxyfired, oxycombustion, oxyfuel*

### 1. Introduction

The wording "zero emissions" is popularly applied to nuclear or renewable energy. In this paper it refers to hydrocarbon fuel fired energy production that does not produce emissions. The interest in fossil fuel fired zero emission power plants (ZEPPs) has greatly increased recently due to the growing awareness of the reality of climate change. In operation renewable energies are carbon neutral and so present a favourable solution to the problem of greenhouse gas emissions. Unfortunately renewable energy sources are currently underdeveloped in comparison to fossil fuel-based technologies. Much work is required before such energy sources will produce a major portion of our energy. Nuclear power is another method of power production that does not contribute in operation to the global warming problem; however, acceptance of nuclear power by the public is quite low, and while there is a revival of nuclear energy worldwide, particularly in Asian countries such as China, India, Korea, Japan, some countries are attempting to reduce their reliance on nuclear power. In Germany, for example, it is planned to phase out all the existing nuclear power plants within two decades

Fossil fuels are well understood by the power industry, and are still relatively cheap and abundant. There is at least as much oil still available in the world as has been burned since the Industrial Revolution, and far more methane is available than has so far been consumed. For good or ill, fossil fuels will remain an integral part of the energy production mix for decades to come. Unfortunately combustion of these fuels produces carbon dioxide, the main contributor to global warming.

ZEPPs offer a method of producing energy from fossil fuels without emitting carbon dioxide. These plants could replace decommissioned power plants, including nuclear plants.

There are many technologies utilising zero emission combustion of fossil fuels, not all of which involve power production. The interested reader is referred to the Zero Emission Technologies for Fossil Fuels: Technology Status Report, published by the International Energy Agency (IEA, 2002).

Many environmentalists would like to completely end fossil fuel consumption as a response to the problem of global warming. The authors disagree completely with this response. It

§ The original version of this paper was reviewed by IJoT. This revised version based on the reviews of IJoT appears also in the Proceedings of 5th Annual Carbon Sequestration Conference 5-11 May 2006 (Alexandria, VA) as paper 011 electronically.

\* Author to whom correspondence should be addressed

is not the fossil fuels in themselves that are a problem – it is the way in which they are burned. Through the use of ZEPPs, the environment will not suffer as a result of the use of fossils fuels.

ZEPPs must follow the law of conservation of mass. Every atom of fuel or oxidiser entering a plant must leave as ash, emission or effluent. In the ZEPP, all the combustion products are converted to liquid form. In short, **the problem of zero emission translates into the conversion of gaseous emissions into liquid effluents.**

Many methods of carbon capture attempt to clean the exhaust gases after combustion by using absorption and / or adsorption, or to extract carbon from the fuel. All of these attempts lead to large mass exchangers. Some produce impure streams of carbon dioxide and none remove all of the carbon dioxide from the exhaust. In short, these are not zero emission power plants, and as such are beyond the scope of this report. The only truly zero emission form of combustion in existence today is pre-combustion gas separation, namely combustion of fuel using oxygen instead of air, usually diluted with either CO<sub>2</sub> or water vapour. This produces an exhaust stream containing only carbon dioxide and water vapour, which are easily separated by condensing out the water vapour. The pure carbon dioxide stream is then compressed and condensed to produce a manageable effluent of liquid CO<sub>2</sub>, which can be sold or sequestered. This approach is often called oxyfiring or oxyfuel. *Figure 1* shows a schematic of the various methods of carbon capture. Oxyfiring is the left downward branch in the picture.

The demand for CO<sub>2</sub> in world industry was evaluated as 1.6% of the CO<sub>2</sub> released to the atmosphere by power plants (Pechtl, 1991). This implies that if zero emission power generation was to be implemented on a global scale, the sequestration of CO<sub>2</sub> would be unavoidable.

The wording “zero emissions” can be challenged for two reasons. Firstly some cycles convert the liquid water back to water vapour and emit it to the atmosphere. In this case the cycle is not strictly zero emission; however, water vapour is not a pollutant or greenhouse gas. Secondly, some cycles intend for the carbon dioxide to be of high purity, requiring removal of contaminants. Some carbon dioxide will probably escape with these contaminants. If the carbon dioxide is destined for storage, however, it does not require a high purity, and the contaminants can be stored along with the carbon dioxide. The authors acknowledge that there may be some cases in this paper in which the wording “zero emissions” is not strictly accurate.

All values given in this paper are taken from the referenced papers and are subject to the varied

assumptions and in some cases mistakes in those papers. They were calculated using different assumptions, models and boundary conditions. This paper is only a history of zero emission cycles, not a comparative evaluation of the different cycles. Therefore the values given here, particularly the efficiencies, should be considered as a guide only.

The compression of the carbon dioxide reduces the efficiency of the plant, but the reduction may be acceptable given the damaging effects of carbon dioxide emissions. Production of oxygen further reduces the efficiency. The most mature method of oxygen production is cryogenics, an energy intensive process involving freezing air. Ion transport membranes offer a much more efficient method of producing oxygen, with the result that many ZEPP cycles incorporate these membranes. This paper presents the history and current state of the art of these cycles.

## 2. Early Attempts

### 2.1 The theory is conceived

To our knowledge, the first mention of a zero emission power unit is documented by Degtiarev and Gribovski (1967). This system integrates air separation, power generation, combustion of a gas in a mixture of CO<sub>2</sub> and oxygen, and production of liquid CO<sub>2</sub>. The only emission is the cold nitrogen from air separation. The aim of the unit is cogeneration of electric power and carbon dioxide for industry. Both authors were students of Professor D. Hochstein in the Odessa Polytechnic Institute who proposed high pressure carbon dioxide as the working fluid in a Rankine cycle (Hochstein, 1940). At that time the greenhouse effect was unknown.

Recently CO<sub>2</sub> as a working substance was proposed by Tokyo electric (Ausubel, 2004). This is a gas turbine cycle with the exhaust gases condensed, compressed, heated and returned to the combustion chamber. The cycle called for 1500°C and 400 atm at the turbine inlet, which seems rather optimistic. This cycle owes much to Professor Hochstein's work.

Marchetti (1979) proposed combustion of fuel in a CO<sub>2</sub>/O<sub>2</sub> mixture, followed by CO<sub>2</sub> sequestration in the ocean. The mass balance for fuel, oxygen and CO<sub>2</sub> is given.

The concept of total emission control combined with enhanced oil recovery was described by Steinberg (1981). His history of carbon mitigation technologies (Steinberg, 1992) describes his pioneering work in this area from 1981 to 1990.

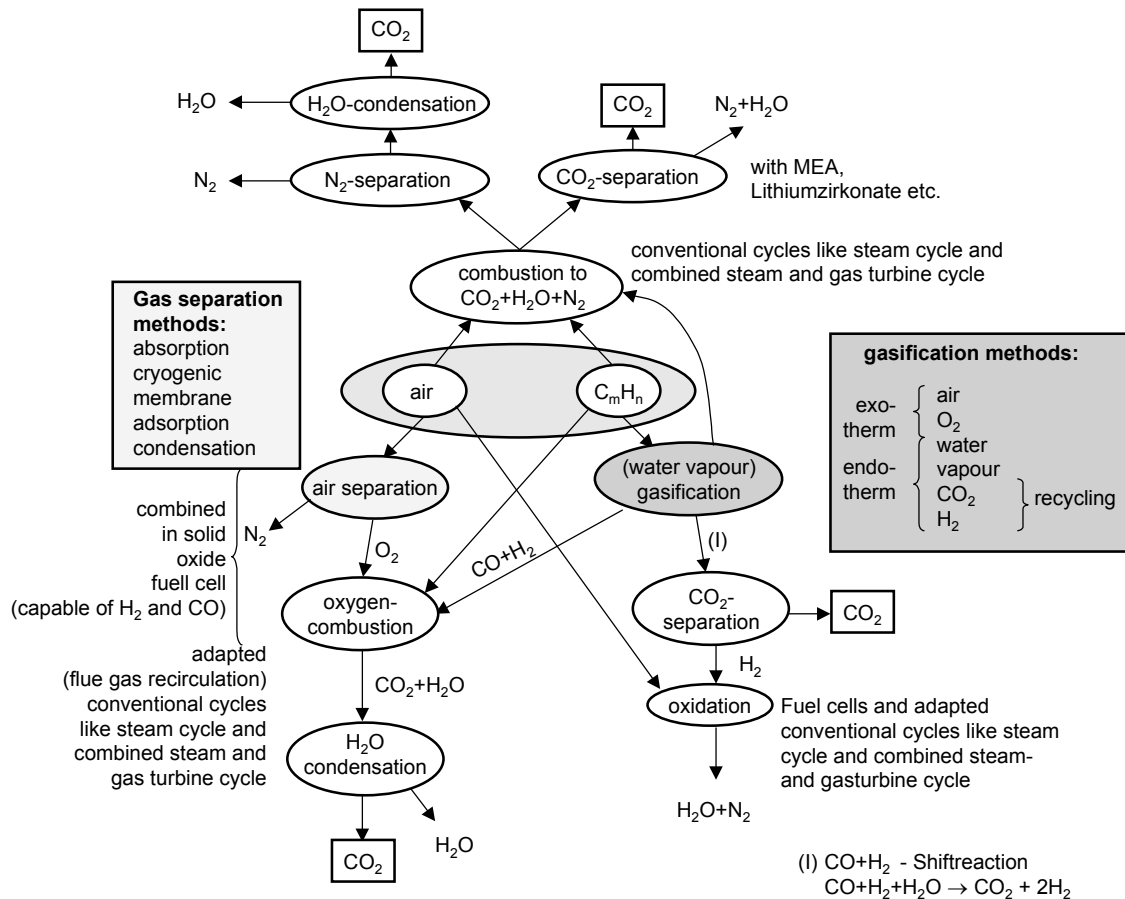

Figure 1. The various methods of carbon capture (Leithner, 2005).

Another history of various zero emission cycles was presented by Yantovski and Degtiarev (1993). For each of the two possible re-circulating substances ( $\text{H}_2\text{O}$  and  $\text{CO}_2$ ) the external combustion (Rankine cycle) or internal combustion (oxyfired) branches are identified. The latter is divided into many particular cases. Known data on cycle efficiencies are compared on a graph, which reveals a much higher efficiency using  $\text{CO}_2$  recirculation as opposed to  $\text{H}_2\text{O}$  recirculation.

A Rankine cycle using zero emission combustion of coal powder was well documented in Argonne Lab. by Wolsky (1985), and Berry and Wolsky (1986). Coal fired zero emission combustion was also investigated by Nakayama et al. (1992), who concluded "O<sub>2</sub>/CO<sub>2</sub> combustion process will provide an effective pulverised coal-fired generating system for CO<sub>2</sub> recovery." Only cryogenic oxygen was considered at that time, which resulted in a cycle that was not economically viable. However more recent investigation into a zero emission coal cycle using ion transport membranes has begun in the Technical University of Aachen (Renz et al., 2005). This cycle, named oxycoal-AC, is presented as having a 41% efficiency for a

400MW plant. This cycle is essentially the same as the Milano cycle (Romano et al., 2005), which also claims a 41% efficiency.

Pak et al. (1989) give a description and schematic of a ZEPP cycle with CO<sub>2</sub> recirculation. However, the need to deflect combustion-born water from the cycle is missed.

Lorentzen and Pettersen (1990) present a ZEPP cycle in which gas is combusted in a CO<sub>2</sub>/O<sub>2</sub> mixture. They not only present the scheme, but also the T-s diagram on which the thermodynamic losses are clearly indicated. These authors have much experience in the use of CO<sub>2</sub> in refrigerators.

Pechtl (1991) consider a ZEPP cycle with CO<sub>2</sub> re-circulation and give some figures, subsequently confirmed by other authors. If the efficiencies of an ordinary 500 MW coal-fired power plant and an equivalent ZEPP are compared, the efficiency drops from 38.9% to 36%. The liquefaction of CO<sub>2</sub> takes 5.3% of the generated power.

Yantovski (1991) presents, in some detail, a schematic for a ZEPP with combustion of natural or coal-derived gas in an O<sub>2</sub>/steam mixture, with triple turbine expansion, CO<sub>2</sub> separation for

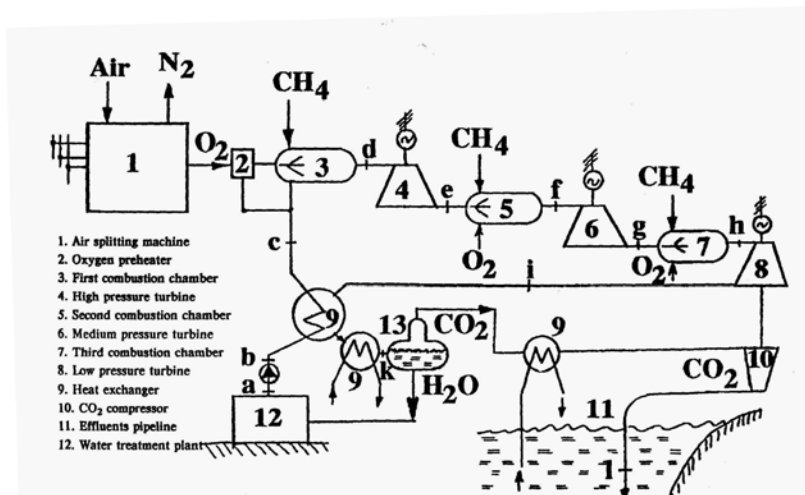

Figure 2. Power plant without exhaust gases (Yantovski, 1991).

sequestration and water re-circulation. Estimation of the cycle efficiency by means of a T-s diagram, at a temperature of 750°C before each of the three turbines, gives an efficiency of 37%. In this paper the practice of emitting carbon dioxide into the atmosphere was likened to the medieval practice of emptying chamber pots into the streets and neighbours' gardens.

The cycle presented in that paper and shown in Figure 2 comprises an air splitter, from which nitrogen is returned to the atmosphere and oxygen is diluted with recirculated water vapour and burned with methane in a combustion chamber, before entering the turbine. The exhaust is cooled, the water separated out for recirculation and the CO<sub>2</sub> compressed for sequestration. The turbine inlet temperature of 750°C was based on a turbine without blade cooling. Yantovski et al. (1992) presented a computer simulation of this ZEPP at higher turbine temperatures. At the highest turbine inlet temperature of 1300°C before the turbines, the efficiency does not exceed 40%. The low efficiency is caused by the very high latent heat of water and the inability to recuperate the large enthalpy of condensing steam. As water is the recirculated substance, this turbine inlet temperature may be optimistic

## 2.2 Industry first becomes interested

Five years after Yantovski's paper, Clean Energy Systems (CES) patented a similar cycle, in which fuel, oxygen and water enter a combustor based on rocket engine technology (Beichel, 1996). This produces a very high temperature jet of 90% steam with 10% CO<sub>2</sub>. Further stages dilute the mixture with more water, increasing the mass flow rate and reducing the temperature. As turbine technology improves, these stages may be removed, increasing the turbine inlet temperature and

allowing the plant to increase in efficiency as technology improves. The turbine exhaust is cooled in stages, condensing out the water for recirculation, and the CO<sub>2</sub> is compressed for sequestration. The oxygen is produced by an unspecified air separator, which may be cryogenic or ITM based. A 5MW demonstration plant in Kimberlina, California, began operating in March 2005. The oxygen is currently produced externally, but an onsite air separation plant is planned. A 10MW<sub>thermal</sub> combustor has been successfully tested. The Kimberlina plant is the first zero emission power plant in the world. The cycle is shown in Figure 3.

Due to the use of water rather than carbon dioxide recirculation, the thermodynamic efficiency seems to be limited to 40%. In recent years the cycle has been further developed. The Kimberlina plant, always intended to be a demonstration plant rather than a commercial enterprise, will soon be joined by a commercial 50 MW plant in Norway. This new plant will use the developed cycle, in which nitrogen from the air separator is used to provide power. This new scheme (Marin et al., 2005) is shown in Figure 4.

The use of nitrogen offers a significant benefit: the high pressure nitrogen is heated by the combustion gases and produces work. This combats the inability to recuperate the latent heat of water and is a real achievement in the development of the CES cycle.

Some technical data for this final cycle, called the Zero Emission Norwegian Gas (ZENG) cycle, is shown in TABLE I. The efficiency of 45% is not too high; some cycles using CO<sub>2</sub> as a working substance have higher predicted efficiencies, but these cycles usually assume very high turbine isentropic coefficients.

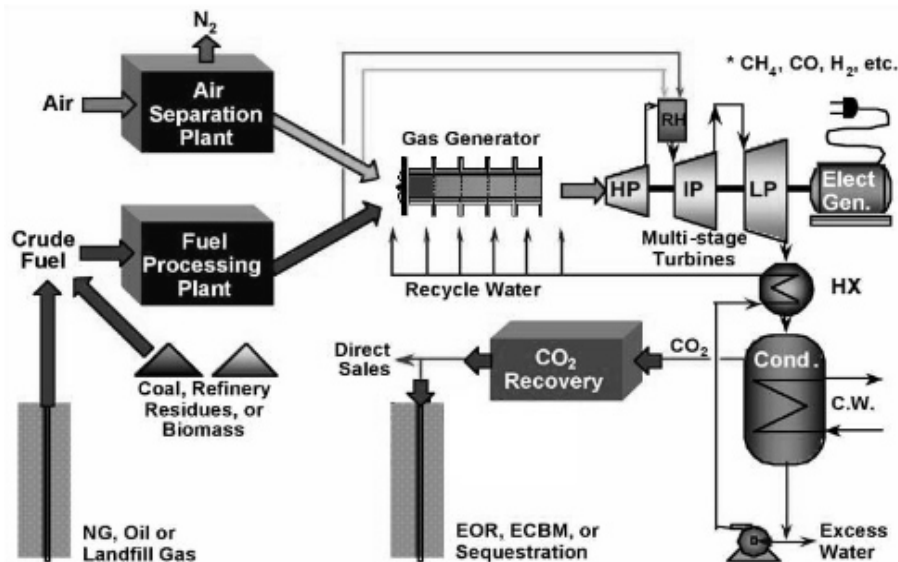

Figure 3. Clean energy systems cycle (Anderson et al., 2002).

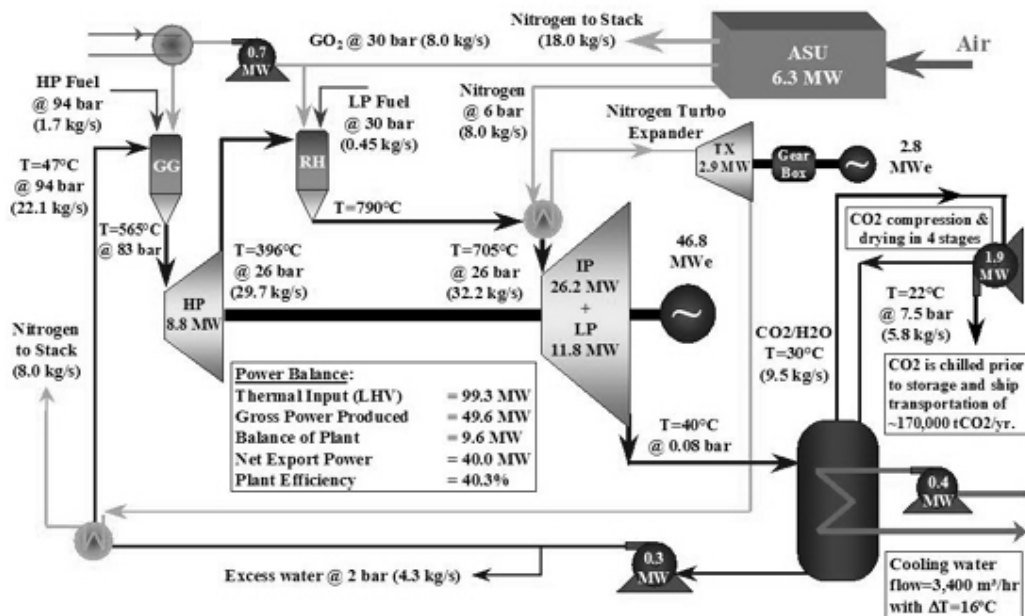

Figure 4. The ZENG project cycle (CO<sub>2</sub> Norway, 2005).

### 2.3 Continued development

Bolland and Saether (1992) present a ZEPP combined cycle – a gas turbine with combustion in an O<sub>2</sub>/CO<sub>2</sub> mixture and a bottoming ordinary Rankine cycle. The production of oxygen and compression of CO<sub>2</sub> combine to reduce the efficiency from 56% (based on a state-of-the-art air-based cycle) to 41%. The same paper also presents a single stage steam turbine cycle with combustion in an O<sub>2</sub>/steam mixture. The maximum efficiency of this cycle at 1550K is given as 38.5%. This paper also gives useful economic data on equipment costs.

De Ruyck (1992) proposed an original ZEPP cycle involving water evaporation in a

mixture with CO<sub>2</sub>. Extremely high efficiencies of up to 57% were claimed. These figures, however, were not confirmed in later papers.

Holt and Lindeberg (1992) considered an integrated complex comprising a ZEPP with enhanced oil recovery. They concluded that two-thirds of the CO<sub>2</sub> produced by combustion in a ZEPP might be returned underground to the same place from where the fuel was extracted.

Van Steenderen (1992), considered the combined gas / steam ZEPP in more detail. At 20 bar and 1050°C at the inlet to the turbine, an efficiency of 44% is reported.

TABLE I. TECHNICAL DATA FOR THE ZENG CYCLE (MARIN ET AL., 2005).

"Optimised" Cycle Summary Data	
Thermal power input	114 MW
Gross power output	58.6 MWe
Parasitic power	8.1 MWe
Net power	50.5 MWe
Overall cycle efficiency	~ 45 %
Fuel consumption	8 210 kg/h
Oxygen consumption	32 760 kg/h
Cooling water flow (total)	~ 4 300 m <sup>3</sup> /h
Excess water production	19.0 m <sup>3</sup> /h
HP Turbine inlet pressure	150 bar
HP Turbine inlet temperature	600 °C
HP Turbine exhaust temperature	~ 320 °C
IP Turbine inlet pressure	22.0 bar
IP Turbine inlet temperature	698 °C
IP Turbine exhaust temperature	~ 390 °C
CO <sub>2</sub> / Steam Condenser pressure	3.0 bar
LP Steam Rankine Cycle	
LP Turbine inlet pressure	1.6 bar
LP Turbine inlet temperature	356 °C
LP Turbine exhaust temperature	24 °C
Steam Condenser pressure	0.03 bar

Yantovski et al., (1993, 1994a), Wall et al., (1995) present a 10 MW ZEPP cycle with liquid CO<sub>2</sub> co-generation, the latter being used to enhance oil recovery. The efficiency is presented as 48% at a turbine inlet temperature of 1000°C and pressure of 40 bar. The Aker Company in Norway began a similar project 5 years after these papers.

A highly efficient ZEPP cycle with CO<sub>2</sub> recirculation and gas combustion in an O<sub>2</sub>/CO<sub>2</sub> mixture is described in detail by Yantovski et al. (1994b). This is the CO<sub>2</sub> Prevented Emission Recuperative Advanced Turbine Energy (COOPERATE) cycle, shown in Figure 5. The efficiency range is given as 46.9% to 55.2% for turbine inlet temperatures between 950°C and 1350°C and pressures between 4 and 240 bar.

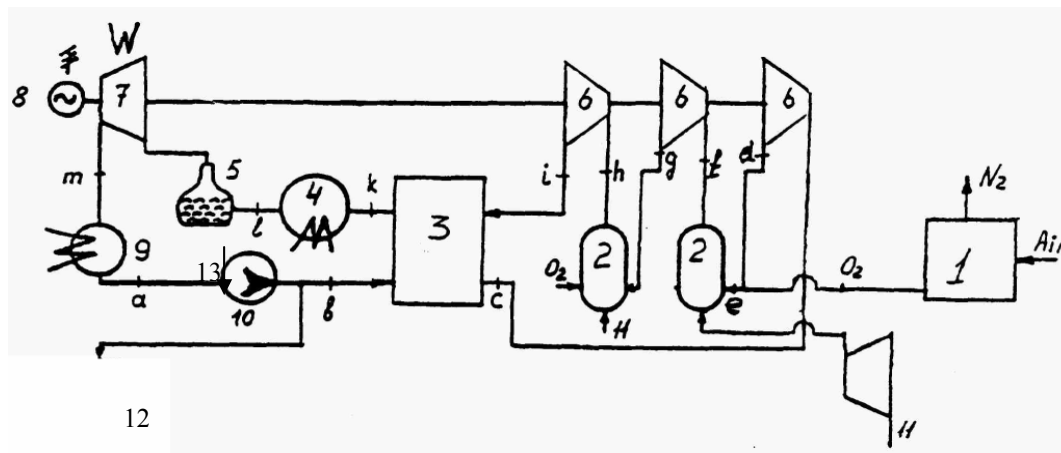

Figure 5. The COOPERATE-demo cycle (Yantovski, 1994c).

1-air separation unit; 2-combustion chamber; 3-recuperator; 4-cooling tower; 5-water separator; 6-turbine; 7-intercooled multistaged compressor; 8-generator; 9-CO<sub>2</sub> condenser; 10-CO<sub>2</sub> pump; 11-fuel; 12-depleted well or other CO<sub>2</sub> storage.

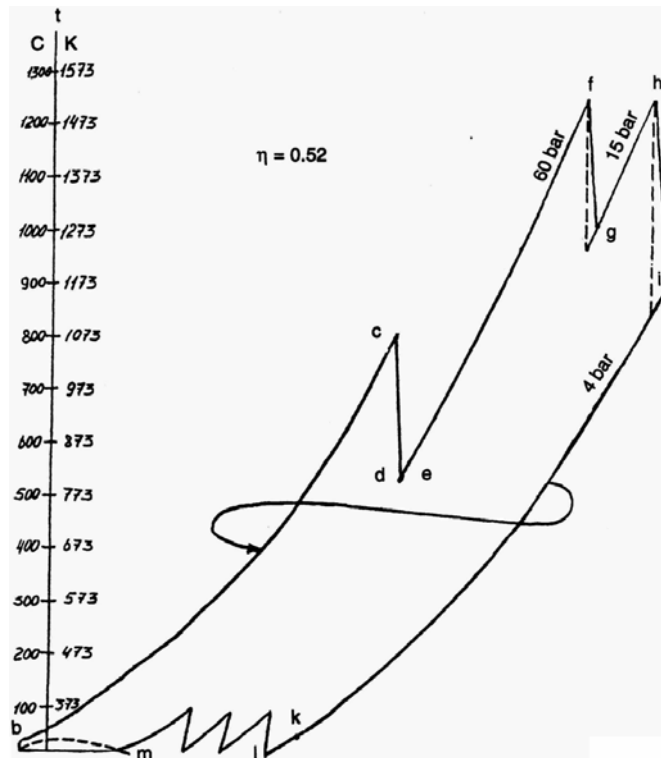

Figure 6. *T - s* diagram of COOPERATE-demo cycle (Yantovski, 1994c).

TABLE II. COMPARISON OF COOPERATE AND COMBINED CYCLE (YANTOVSKI, 1996).

	Efficiency	Cost of electricity [c/kWh]	CO <sub>2</sub> emissions [g/kWh]
Standard cycle	52.2%	4.00	360
COOPERATE	54.3%	5.55	0

Discussions with turbine manufacturers established that the temperature and pressure before the first turbine in the COOPERATE cycle were not feasible in the foreseeable future. This led to further development of the cycle by Yantovski (1994c), resulting in an efficiency of 50% based on more realistic turbine inlet states of 600°C at 240 bar and 1300°C at 40 bar. This highly efficient realistic cycle (COOPERATE-demo) is described as quasi-combined as it consists of two parts: a high pressure Rankine cycle using CO<sub>2</sub> and a low pressure Brayton cycle using the same CO<sub>2</sub>. A comprehensive description of almost all such zero emission cycles can be found in the book by Goettlicher (1999). The COOPERATE cycle belongs to "Process Family II" in the book.

Yantovski (1996) compares the COOPERATE cycle to a standard combined cycle, as shown in TABLE II. The payback period was estimated as 3 years for the COOPERATE cycle if a fuel with a negative price, such as a used lubricant, is used. In the USA about 1 Mton/year of used lubricant is available. In the paper the benefits of enhanced oil recovery are described along with storage of carbon dioxide in brine. Using data on the

amount of brine in the hydro-lithosphere, a storage capacity of 2 million Gton of CO<sub>2</sub> in brine solution is estimated. This could protect the atmosphere for the foreseeable future. It should be noted that this figure is an upper limit and local restrictions should be taken into account in case studies.

A big problem with the COOPERATE cycle is the non-condensable gases in the CO<sub>2</sub> condenser. As a radical remedy, it was proposed that CO<sub>2</sub> condensation could be avoided by compressing the CO<sub>2</sub> flow immediately after exiting the cooling tower, without allowing the compression process to cross the saturation line. This version of the COOPERATE cycle is the MATIANT cycle (Mathieu, 1998). Detailed calculations of the various versions of the MATIANT cycle (Mathieu et al., 1999) show that the loss of efficiency resulting from cryogenic air separation and CO<sub>2</sub> compression is about 11.5 – 14.5 percentage points, compared to a state-of-the-art cycle operating between the same thermodynamic parameters. The cycle involves staged combustion with a 2-stage expansion, and is shown in Figures 7-8, along with some technical information, given in TABLE III,

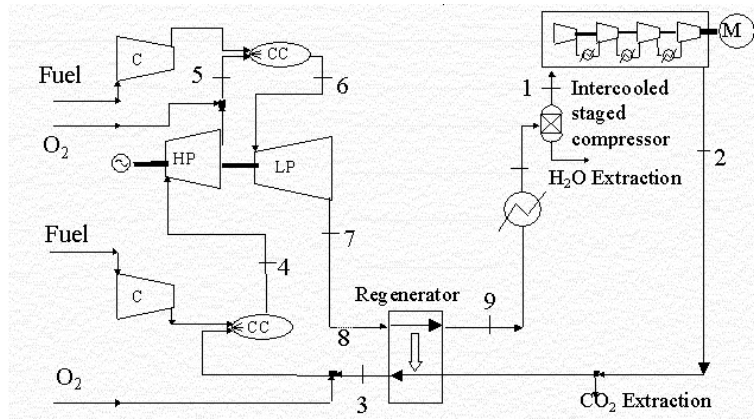

Figure 7. The MATIANT cycle (Mathieu, 1998).

TABLE III. OPERATING PARAMETERS OF THE MATIANT CYCLE (MATHIEU, 1998).

Upper cycle pressure	60 bar	Pinch-point at the regenerator outlet	20°C
Lower cycle pressure	1 bar	Maximum inlet temperature in the regenerator	700°C
Pressure drop in the combustion chamber	3 % $p_{su}$	Expanders' inlet temperature (TIT)	1300°C
Isentropic effectiveness of the 3 expanders	0.87	Lower cycle temperature	30°C
Isentropic effectiveness of the O <sub>2</sub> compressors	0.75	Isentropic effectiveness of the fuel compressor	0.75
Isentropic effectiveness of the intercooled CO <sub>2</sub> compressor : 0.85 for the 3 first stages – 0.8 for the last one			

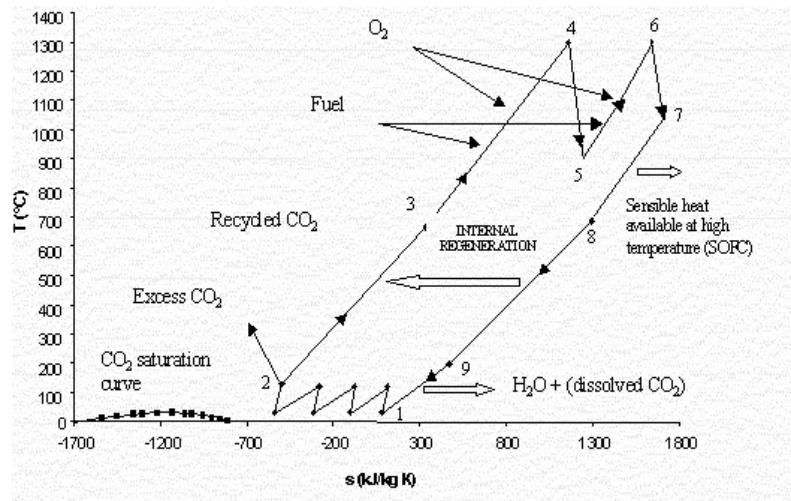

Figure 8.  $T - S$  diagram of the Matiant cycle (Mathieu, 1998).

1-2: intercooled staged compressor; 2-3: upper pressure part of the regenerator; 3-4: high pressure combustion chamber; 4-5: high pressure expander; 5-6: low pressure combustion chamber; 6-7: high temperature heat exchanger; 8-9: regenerator; 9-1: water cooler / separator

Based on the data in TABLE III, the cycle efficiency is around 45% when the fuel is natural gas, the turbine inlet temperature is 1300°C, and the exhaust gas temperature is limited to 700°C. If the exhaust gases are cooled by a steam reheat cycle, the efficiency climbs to 49%.

In order to efficiently use the heat at a higher temperature than 700°C, a solid oxide fuel cell (SOFC) was integrated into the cycle between points 7 and 8, as shown in Figure 8 (Mathieu and Desmaret, 2001).

The isentropic effectivenesses in the Matiant cycle are quite conservative and the results of the calculations are reliable and comply with technical limitations on the temperature at turbine inlet and exhaust. When the upper pressure changes from 140 bar (at 1200°C) to 220 bar (at 1400°C), the cycle efficiency increases from 44.3% to 46.05%.

A coal-fired cycle with integrated gasification (IGCC-Matiant) has also been developed (Mathieu and van Loo, 2005). At 1250°C and 120 bar the calculated efficiency is 44.8%, which is rather high for a coal-fired ZEPP.

Ruether et al. (2000) described an integrated system with “oxygen-blown dry coal entrained gasification providing fuel to the Matiant cycle. Oxygen for both the gasifier and the Matiant cycle is prepared by use of an Ion Transport Membrane (ITM) instead of a conventional cryogenic air separation unit.” The thermal efficiency of the overall cycle is 43.6% of the higher heating value of the coal, and 99.5% of the carbon dioxide produced is captured.

The Graz cycle was first introduced by Jericha et al. (1995) and has been continually developed by researchers at the Institute of

Thermal Turbomachinery and Machine Dynamics at Graz University of Technology. It is similar to the Clean Energy Systems cycle in that steam is recirculated to the combustion chamber, however it is more complex than the CES cycle. It was developed as an adaptation of a hydrogen/oxygen cycle published by Jericha (1985). The cycle was also developed for a coal-derived syngas plant (Jericha et al., 2000). The exhaust gas (80% steam and 20% carbon dioxide) powers a high temperature turbine, after which about half is cooled, compressed and re-enters the combustion chamber, while the rest enters an intermediate pressure turbine. After the intermediate stage, a portion is bled off and the water condensed out. The rest enters a low pressure turbine and is then cooled, with the water condensed out. The CO<sub>2</sub> is captured at the pressure of the intermediate turbine (atmospheric pressure). The water captured at low pressure is pumped to a very high pressure and heated. It then enters a steam turbine before returning to the combustion chamber. An efficiency of 56.8% of higher heating value was claimed for this cycle, however the cycle assumes a supply of pure oxygen, and the carbon dioxide is provided at atmospheric pressure. The cycle is shown in Figure 9.

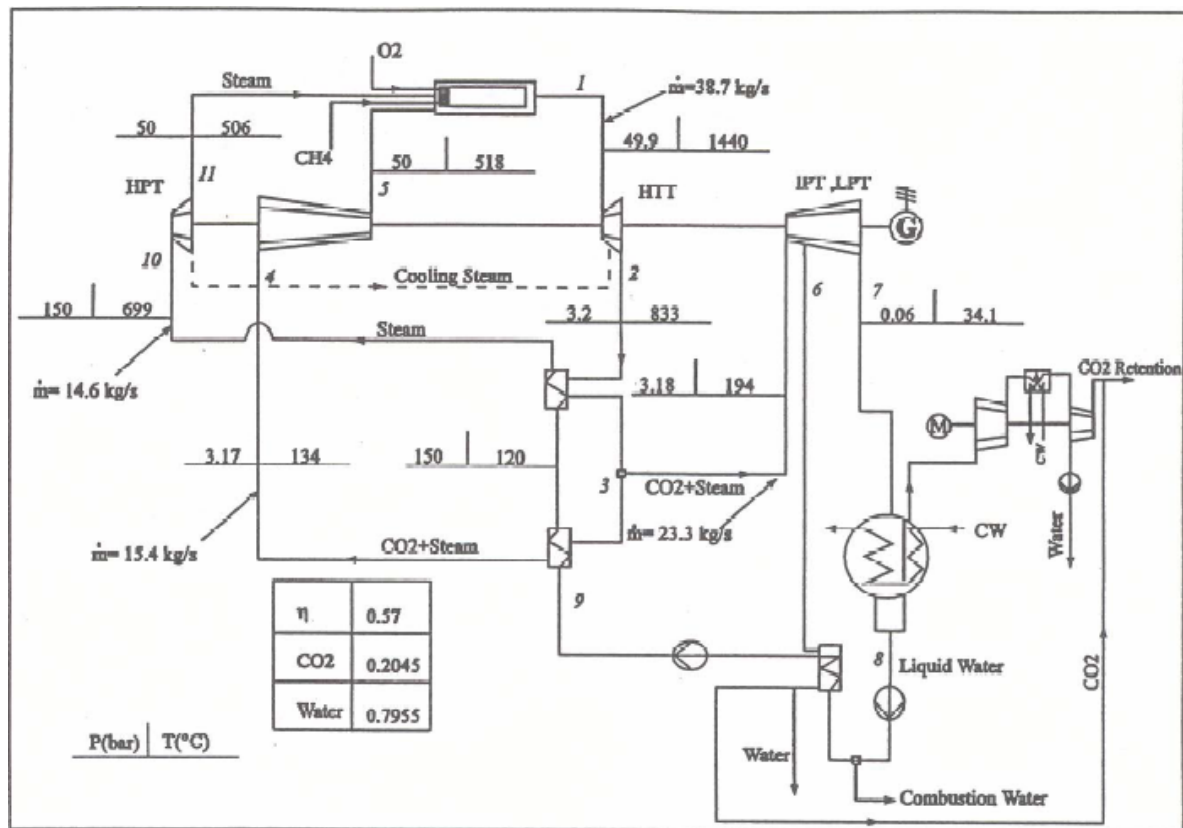

Figure 9. The original Graz cycle (Jericha et al., 1995).



## 2.5 ZEPP cycles incorporating oxygen ion transport membranes

As mentioned above, cryogenic air separation has a very detrimental effect on the performance and efficiency of ZEPP cycles. Oxygen ion transport membranes (OITMs) offer the possibility of oxygen production without significantly adversely affecting the efficiency, and probably at a lower cost than cryogenic production. In fact, by using the air stream as a bottoming air turbine cycle, production of oxygen using OITMs can actually increase the efficiency of a ZEPP. OITMs currently have a maximum operating temperature of about 1000°C, and this can limit some cycles.

The simplest ZEPP cycle incorporating an ITM reactor is shown in *Figure 11*. The ITM provides oxygen for combustion, with the heat of combustion used to provide heat to an ordinary Rankine cycle. The cycle is limited by the temperature of a Rankine cycle (state-of-the-art steam turbines have a maximum temperature of about 600°C), but this temperature is acceptable for the OITM ceramic. At a temperature of

540°C with a reheated Rankine cycle, the efficiency is 35.7% (Levin et al., 2003).

A well developed example of a ZEPP incorporating ITMs is the AZEP (Advanced Zero Emission Power) cycle which comprises a novel combustor integrated with a ceramic membrane and a heat exchanger (Sundquist et al., 2001), shown in *Figure 12*.

Here, the simplified CO<sub>2</sub> portion of the cycle does not allow a high efficiency to be achieved. The intention of the AZEP authors is to avoid the use of CO<sub>2</sub> turbines, which are not currently available. They have integrated the OITM and combustion chamber: the membrane wall simultaneously conducts oxygen to the fuel side and heat to the air side. The main turbine is the air turbine (referred to in *Figure 12* as the gas turbine), powered by the oxygen-depleted air from which half of the oxygen has been removed. This turbine drives both the air compressor and the electrical generator. The combustion gases do not drive a turbine, and are used to provide heat to a bottoming Rankine cycle.

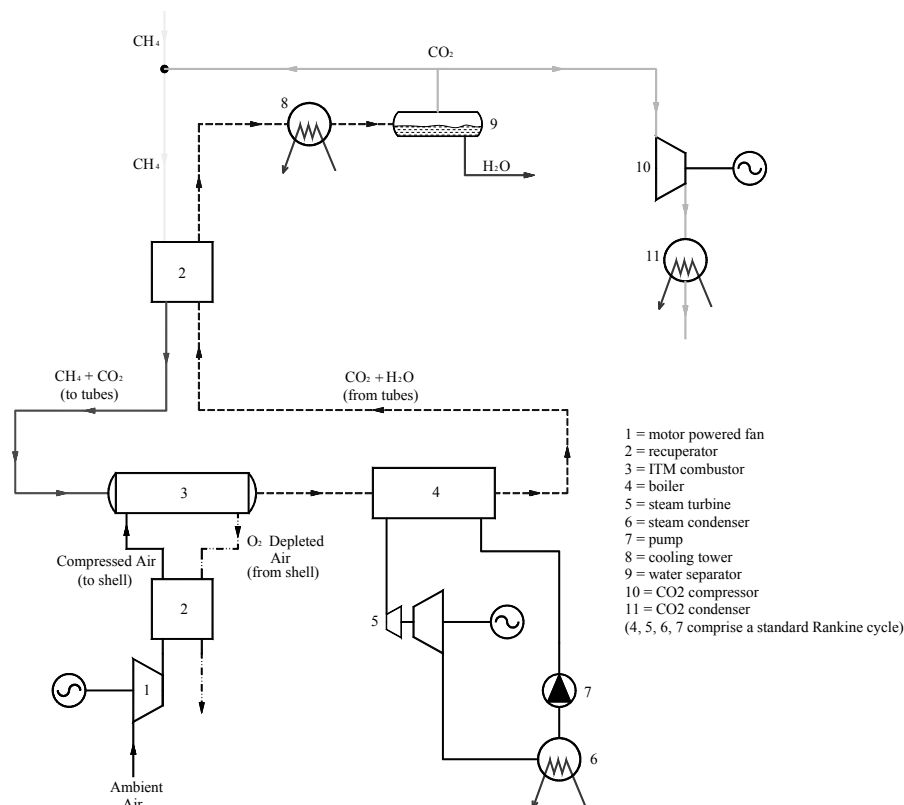

*Figure 11. Simplest ZEPP cycle incorporating an ITM reactor (Levin et al., 2003)*

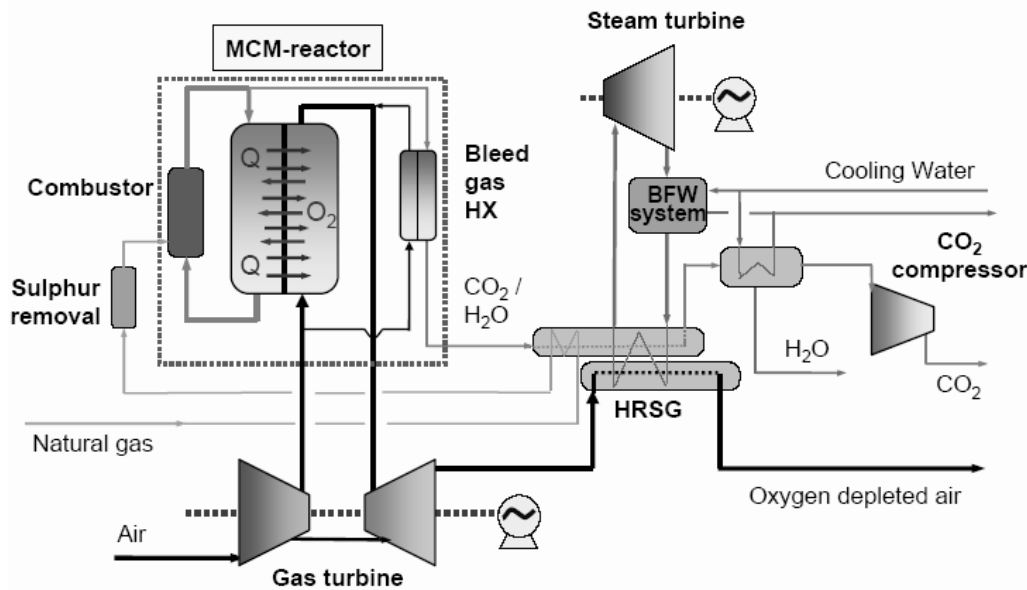

Figure 12. The AZEP cycle (Sundquist and Eklund, 2004).

MCM = mixed conducting membrane; HX = heat exchanger; BFW = boiler feed water; HRSG = heat recovery steam generator

This cycle demonstrates the problem of using OITMs to provide oxygen: the OITM cannot be heated to too high a temperature, but the combustion should occur at the highest possible temperature for high efficiency using a gas turbine. The AZEP cycle was compared to a V94.3A combined cycle power plant, the efficiency of which is 57.9%. *“The penalty in thermal efficiency for the AZEP... is 8.3 percentage points. This high loss is mainly due to the reduced turbine inlet temperature (1200°C) that causes significant power loss both in the gas turbine and in the steam cycle”*. The turbine inlet temperature can be increased by optional firing of additional fuel in the heated air stream before entry to the gas turbine. The combustion products of this additional firing are released to the atmosphere. By adding enough extra fuel at this point, the AZEP’s efficiency is claimed to increase from 49.6% to 53.4%, but in this case only 85% of the carbon dioxide is captured (Sundquist et al., 2004). This retention rate is similar to that of a cycle with post-combustion CO<sub>2</sub> absorption. An economic analysis of the AZEP cycle showed that a carbon emission tax of €31 – €40/ton would make the AZEP with 100% carbon capture as economically attractive as the V94.3A plant (Sundkvist and Eklund, 2004).

If a ZEPP cycle is to be competitive with existing cycles without tax incentives, it must have a similar efficiency. This requires removing the restriction on cycle upper temperature caused by the membrane reactor.

The ZEITMOP (Zero Emission Ion Transport Membrane Oxygen Power) cycle

(Yantovski et al., 2002) was developed independently of the AZEP cycle. The simplest version of this cycle is the gas-fired one, shown in Figures 13-14, although the concept behind the cycle can also be applied to other fuels, e.g. pulverised coal.

In the ZEITMOP cycle the ITM reactor is remote from the combustion chamber, allowing much higher combustion temperatures to be achieved. After separation of combustion products the carbon dioxide is cooled and compressed, then heated and expanded (i.e. a Rankine cycle) before entering the ITM to be mixed with oxygen. This mixture then enters a separate combustion chamber. As a result, the ZEITMOP cycle can have a higher combustion temperature and hence a higher efficiency. If the turbine inlet temperature is 1500°C, the ZEITMOP cycle efficiency is claimed as 56%. This temperature limit depends only on the turbine, not on the ITM reactor. Current turbines inlet temperatures are of the order of 1300°C, at which temperature the ZEITMOP efficiency is claimed as 46%.

The ZEITMOP cycle has not been optimised, so there remains hope for an increase in efficiency through optimisation. As this cycle could be developed for all types of fossil fuels, it represents one of the best options for the replacement of decommissioned power plants at the beginning of this new millennium.

The use of CO<sub>2</sub> turbines should not be an insurmountable technical problem. Such turbines were investigated by the Esher-Wyss Company in Switzerland about 40 years ago



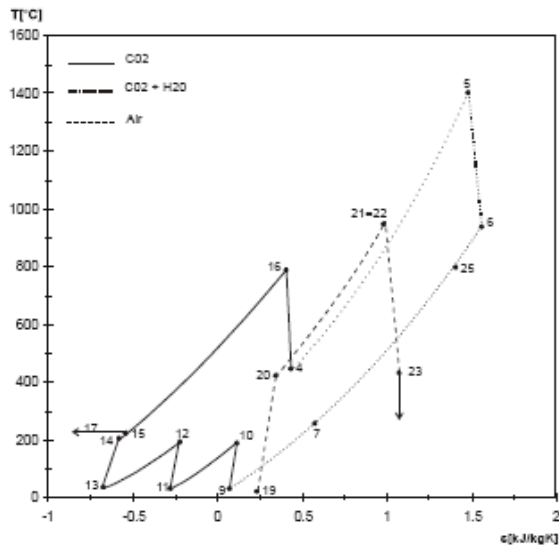

Figure 14. *T - s* diagram of ZEITMOP cycle (Yantovski et al., 2003a).

Siemens, Westinghouse and Praxair collaborated to develop a zero emission fuel cell cycle (Shockling et al., 2001). In a hydrocarbon-fuelled fuel cell, the fuel is fed to the anode side of a fuel cell and air to the cathode side. About 85% of the fuel is used in the fuel cell, and the gas leaving the anode side is normally mixed

with the cathode gas and they are burned together. The heat from combustion is used to preheat the incoming air and fuel, and also to partially reform the fuel. In the system described here the cathode gas is fed to one side of an oxygen ion transport membrane, with the anode (air) gas on the other side. Oxygen passes through the membrane to completely oxidise the cathode gas stream, which then consists entirely of carbon dioxide and water vapour. Fuel cell cycles are very efficient, so this cycle is a promising development in the area of zero emission cycles.

The membrane reactor in this cycle is being developed by Praxair, who are focusing on a tubular membrane concept. The paper gives the results of many tests on the reactor.

Another coal-fired ZEPP incorporating ITMs is the Milano cycle (Romano et al., 2005). It is similar to the AZEP cycle due to the lack of CO<sub>2</sub> turbines and restriction on cycle temperature due to the membrane reactor. The bottoming cycle is an ordinary steam cycle which generates power, whereas the air turbine drives the compressor only. The cycle is shown in Figure 15, along with some technical data, given in TABLE V.

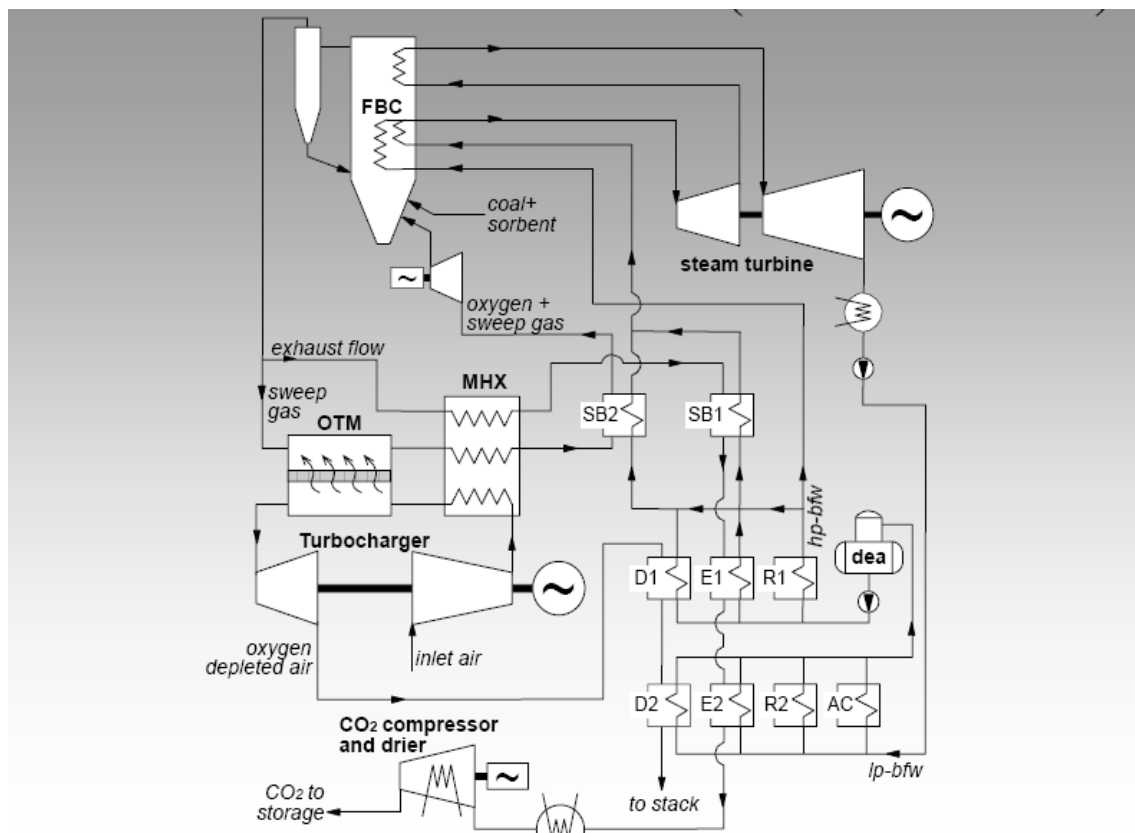

Figure 15. The Milano cycle (Romano et al., 2005).

TABLE V. PERFORMANCE OF THE MILANO CYCLE (ROMANO ET AL., 2005).

FBC - USB Performance calculation		
FBC pressure, bar	1.15	10
Coal LHV input, MW	984.9	984.9
Turbocharger inlet air flow, kg/s	593.5	698.2
Turbocharger pressure ratio	11	20
Turbocharger power output, MW	74.7	69.7
ST power output, MW	404.9	400.6
Net power output, MW	407.2	414.6
Net plant LHV efficiency, %	41.34	41.89

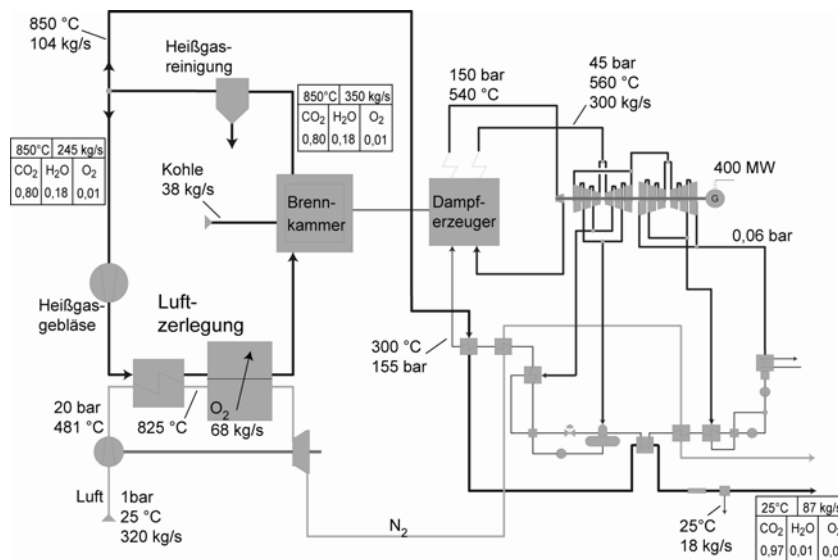

Figure 16. The oxycoal-AC cycle (Renz et al., 2004).

Kohle = coal; Brennkammer = combustion chamber; Dampferzeuger = steam generator; Heißgasreinigung = flue gas cleaner; Heißgasgebläse = flue gas pump; Luftzerlegung = air separator; Luft = air

Increasing the combustion pressure from 1.15 bar up to 10 bar resulted in a negligible increase in the calculated efficiency, which is quite standard for a Rankine cycle (41.34 – 41.89%). Solving the membrane reactor problem is required to make this cycle competitive with other coal-fired ZEPPs.

The oxycoal-AC cycle, developed in Aachen (AC), and presented by Renz et al. (2004, 2005), includes a high temperature membrane unit in which oxygen is mixed with carbon dioxide and water vapor. Pulverised coal is burned in this mixture to provide heat for a Rankine cycle. The system is shown in Figure 16. Note the depleted air is described as N<sub>2</sub> in the diagram. This is incorrect as only oxygen has been removed from the air, other elements remain, e.g. water vapour, argon, carbon dioxide. Also, it is impossible for 100% of the oxygen to be removed by the membrane, some must remain as the oxygen partial pressure on the feed side must be greater than that on the permeate side.

The efficiency for this cycle, 41%, was calculated based on a simulation using Ebsilon (Renz et al., 2005). It is very similar to the efficiency of the Milano cycle, which is unsurprising as the two cycles are very similar, although the Milano cycle uses fluidised bed combustion and the oxycoal-AC cycle uses pulverised coal.

Commercial interest in oxycoal is strong. The US Department of Energy has granted funding to Babcock and Wilcox, who are using oxycombustion of coal in wall-fired and cyclone boilers (Anna, 2005). Vattenfall plans to build a 30 MWth pilot plant using oxyfired combustion of coal in Germany (the Schwarze pump lignite fired plant, Berlin). This is scheduled to begin in 2008.

## 2.6 Zero emissions vehicle cycle

Carbon dioxide emissions from vehicles are more of a problem than those from power plants. Vehicle manufacturers seem to focus entirely on

hydrogen or electric vehicles in their attempts to create a zero emission vehicle. Unless the hydrogen or electricity is produced by a zero emission process, these vehicles are not zero emission. The only truly zero emission vehicle cycle of which the authors are aware is the Zero Emission Membrane Piston Engine System (ZEMPES) cycle (Yantovski and Shokotov, 2003b, Yantovski et al., 2004, 2005). Cryogenic oxygen production onboard a vehicle is likely to be unfeasible due to the unavoidable vibration

and inertial forces, which are detrimental to distillation columns, so OITMs are the most attractive option for oxygen production onboard a vehicle. The ZEMPES cycle uses an OITM reactor (ITMR in the schematic) to oxygenate exhaust gases, which are recirculated to the ordinary piston engine. The simplest version of the cycle is shown in *Figure 17*, along with technical information in TABLE VI.

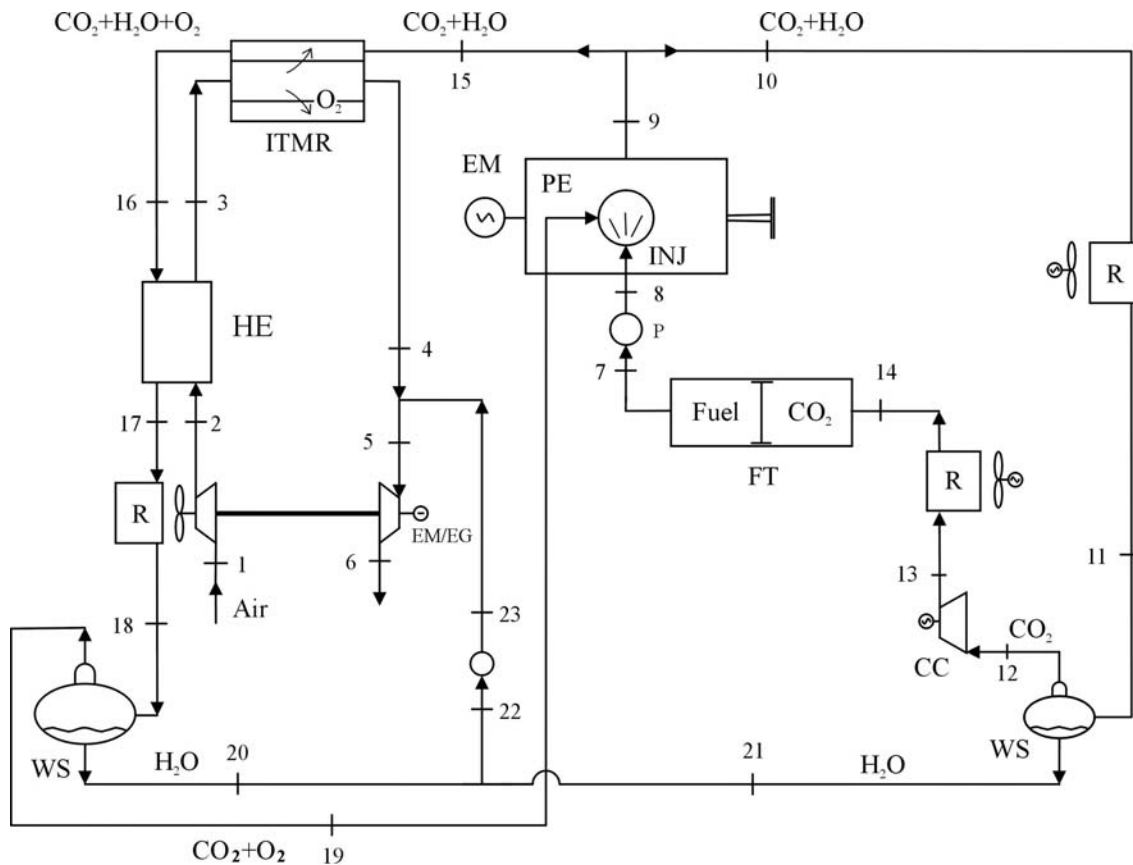

Figure 17. The ZEMPES cycle (Yantovski et al., 2004).

CC=CO<sub>2</sub> compressor, EG=electric generator, EM=electric motor (for starting), FT=fuel/CO<sub>2</sub> tank with sliding baffle, HE=heat exchanger, INJ=fuel injection, ITMR=ion transport membrane reactor, P=pump, PE=piston engine, R=radiator-cooler, TC=air turbocompressor, WS=water separator

TABLE VI. ZEMPES EFFICIENCY (YANTOVSKI ET AL., 2004).

<b>ZEMPES cycle efficiency</b>	
Turbine power	106.35 kW
Compressor power, kW	C1 = 93.1.68, C2= 34.23
Total power	127.4kW
Piston engine indicator power	283.56 kW
Piston engine effective power	235.47 kW
Friction losses	11.76 kW
Radiator fan power	26.7 kW
Fuel energy input	800 kW
Fuel consumption	64.2 kg/hour
Specific fuel consumption	272.4 g/kWh
<b>System efficiency</b>	<b>28 %</b>

The piston engine may be a spark or compression ignition engine. The exhaust gases heat the membrane reactor and are mixed with oxygen there. Obviously not all the exhaust gases can be recirculated; the extra portion born of the fuel and oxygen combustion is removed and separated by condensing out the water. This water may be injected into the air stream before the turbine, making the only emission harmless water vapour (just as in a hydrogen vehicle). Alternatively it could be stored onboard for removal when the vehicle is refuelled, as is done with the carbon dioxide.

To avoid the need for two storage tanks, the carbon dioxide may be compressed and stored in the same tank as the fuel, separated by a sliding baffle. At the refuelling station the carbon dioxide is removed as the fuel tank is filled.

The calculated efficiency of 28% seems to be acceptable for a zero emission vehicle. It can be increased by the addition of an exhaust gas turbine to 37% and a bottoming Rankine cycle to 44% (Yantovski et al., 2005), but such a complicated system is too cumbersome for a real vehicle. Reducing the dilution of the combustion mix may provide an easier method of increasing the efficiency. This option is currently under investigation by Shokotov and Yantovski.

Startup of ZEMPES can be easily implemented by switching off the recirculation, burning the fuel in air, and using the exhaust gases for heating the membrane only. This requires allowing some emissions at startup only. Measuring the carbon dioxide stored onboard allows easy tracking of these emissions. Alternatively some oxygen could be stored onboard for zero emission combustion during startup.

### 2.7 The zero emission industry

All zero emission cycles might be considered as cogeneration of power and carbon dioxide. The quantity of carbon dioxide so produced will probably exceed the industrial demand. The greatest consumer of carbon dioxide is Enhanced Oil Recovery (EOR) and Enhanced Coal Bed Methane Recovery (ECBM). The contemporary and future convergence of the power industry and the oil/gas industry on a zero emission basis was considered by Yantovski and Kushnirov (2000b) and some relevant cycles were discussed by Yantovski (2000c).

Akinfiev et al. (2005) have shown the ultimate goal of CO<sub>2</sub> injection underground: a possible method of converting CO<sub>2</sub> to methane through reaction with fayalite.

The worldwide capacity of gas-fired power plants suitable for AZEP technology from 2020 was estimated to be in the range of tens of GW. It is estimated that the AZEP cycle could be commercially available in less than 10 years,

given a market (Sundkvist and Eklund, 2004).

As mentioned throughout this paper, the Clean Energy Systems plant will soon be joined by a number of other demonstration and commercial plants. In general it appears that ZEPPs are close to commercialisation. The interested reader may find excellent reviews of ZEPPs in Goettlicher (1999, 2003), Bolland (2004a, b), Gupta (2003) and Bredeson (2004). Only the last reference contains ZEPPs with oxygen ion transport reactors. A recent comprehensive review of carbon capture technologies is given by 12 leading professionals from 10 power companies in VGB (2004). Unfortunately this review almost ignores ITM reactors for oxygen production, and mentions only a few membrane technologies, including the AZEP cycle, as examples of very futuristic technologies. The authors of this report claim that carbon capture always reduces electrical efficiency of a cycle. However, this is not necessarily true. For example in the ZEITMOP cycle, the recirculated carbon dioxide undergoes a Rankine cycle, actually adding to the electrical efficiency.

### 3. Oxygen Ion Transport Membranes

In 1899, Walter Hermann Nernst observed the current of oxygen molecules through dense ceramics when heated somewhat. The current of oxygen was similar to the current of electrons in metals under an electrical potential difference. The partial pressure of oxygen played the role of electrical potential. Some years later he discussed this with A. Einstein, and this resulted in the Nernst-Einstein formula:

$$J_{O_2} = \frac{\sigma_i RT}{4Ln^2 F^2} \ln \left( \frac{P'_{O_2}}{P''_{O_2}} \right)$$

Here  $J_{O_2}$  is the oxygen flux,  $F$  is Faraday's constant,  $L$  is the membrane thickness,  $n$  is the charge of the charge carrier (= 2 for oxygen ions),  $R$  is the ideal gas constant,  $T$  is the absolute temperature,  $P'_{O_2}$  is the oxygen partial pressure at the feed surface of the membrane,  $P''_{O_2}$  is the oxygen partial pressure at the permeate surface of the membrane and  $\sigma_i$  represents the material conductivity. This expression clearly identifies the natural logarithm of the oxygen partial pressure ratio as the driving force for the oxygen flux.

An oxygen ion transport membrane is a ceramic membrane made of one of the materials that conduct oxygen ions. They typically have perovskite or fluorite molecular structures, and contain oxygen ion vacancies, i.e. a "hole" in the molecular structure where an oxygen ion fits. When oxygen ions are excited, they can travel through the structure by leaping from vacancy to

vacancy. As the membrane is a dense, impermeable ceramic, no gas can pass through, so the overall effect is one of a material that is permeable to oxygen and no other substance. Bouwmeester and Burggraaf (1996) explain the operation of an ion transport membrane: “Dissociation and ionization of oxygen occurs at the oxide surface at the high pressure side (feed side) where electrons are picked up from accessible (near-) surface electronic states. The flux of oxygen ions is charge compensated by a simultaneous flux of electronic charge carriers. Upon arrival at the low-pressure side (permeate side), the individual oxygen ions part with their electrons and recombine again to form oxygen molecules, which are released at the permeate side”.

As the driving force is the partial pressure difference, pure oxygen can be produced as long as the total pressure on the permeate side is lower than the oxygen partial pressure on the feed side. If air is the feed gas, as is typically the case, this means the pressure on the permeate side must be less than 1/5 of the pressure on the feed side. By diluting the permeate, i.e. using a sweep gas, the oxygen partial pressure ratio can be increased without the need for a high total pressure differential across the membrane. If an oxygen-consuming reaction occurs at the permeate side, the oxygen partial pressure ratio is higher still. The question as to which is better, a *separate* membrane reactor to produce “artificial air” (oxygen with carbon dioxide or water vapour) and a *separate* combustion chamber, or *combined* air separation and combustion in the permeate side, is still open. This question can only be answered by future tests.

To the authors’ knowledge, one of the first papers to describe various schemes for adopting ion transport membranes for use in power production was Dyer et al. (2000). Oxygen production using membrane separation technology for gas-steam power production and internal gasifier integration is described. The authors have not used a sweep gas to remove the oxygen from the permeate side of the membrane, and use the pure oxygen in a coal gasifier. The resulting gas is combusted in air, and the exhaust is released to the atmosphere, so this is not a ZEPP.

ITM reactors have many design problems, but stability is a crucial one. Oxygen flux is inversely proportional to the thickness, and manufacturers are currently making membranes of the order of tens of micrometers thick. These thin dense membranes must be supported on a porous substrate, particularly if there is a difference in pressure ratio across the membrane. The porous substrates may be made of the same or similar material to the membrane, i.e. ceramic. But the reactor operates at high temperatures,

which can cause porous ceramic to sinter, reducing the porosity and hindering performance. Van der Haar (2001) reported that “*Mechanical tests of the porous perovskite support reveals that these could endure an absolute pressure difference of about 30 bar...application of the supports at temperatures close to 1000°C will reduce its porosity due to non-negligible sinter activity at these temperatures*”. These mechanical problems are currently being solved by a number of companies and research groups around the world.

The authors would like to present technical information about currently available ITM reactors, however the main characteristic of any reactor, which is crucial for its size and cost, is the achieved oxygen flux,  $J_{O_2}$ . No manufacturers are currently publishing this information, instead giving information such as the relative increase in oxygen flux during development, or describing the overall size of a reactor in general terms. Foy and McGovern (2005) compared published data from laboratory tests for a number of different ITM materials. Most of these tests were performed on relatively thick samples, of the order of 1 mm. As mentioned above, manufacturers are currently working with thicknesses of tens of micrometres. TABLE VII shows the materials compared, and Figures 18-19 show the results of the comparison.  $P_1$  is the oxygen partial pressure on the feed side and  $L$  is the thickness. The unit of flux is 1 micromole/cm<sup>2</sup>s [= 0.32 g/m<sup>2</sup>s].

The Lawrence Livermore National Laboratory developed a “*global description of the oxygen permeation through dense ceramic membrane*” (Pham, 1997). This theory predicted that “*oxygen flux as high as 100 ml.cm<sup>-2</sup>.min<sup>-1</sup> is possible if the surface of the membrane is coated with a high surface area catalyst layer*”. The limit mentioned here is about 23 g/m<sup>2</sup>s. Many authors assume a membrane flux of 1 g/m<sup>2</sup> s (3.125 μmol/cm<sup>2</sup>s).

#### 4. Oxygen Ion Transport Membrane reactors for ZEPPs

The largest element of the AZEP cycle is the membrane reactor. This large ceramic module operates at temperatures of 1250°C. Air heaters for coal powder fired air turbines are another example of large ceramic bodies at high temperatures. After many decades of work, these air heaters are still a problem. It is possible that development of an integrated OITM/combustion chamber might be more difficult than development of a CO<sub>2</sub> turbine. The current design of the module is shown in Figure 20. Combustion chambers and ITM modules are incorporated into the same chamber.

TABLE VII. ITM MATERIALS COMPARED BY FOY AND MCGOVERN (2005).

Name	Formula	Author	Year
BBCF	$BaBi_{0.4}Co_{0.2}Fe_{0.4}O_{3-d}$	Shao, et al.	2000
BCF	$BaCe_{0.15}Fe_{0.85}O_{3-d}$	Zhu, et al.	2004
BSCF	$Ba_{0.5}Sr_{0.5}Co_{0.8}Fe_{0.2}O_{3-d}$	Wang, et al.	2002
BTCF	$BaTi_{0.2}Co_{0.5}Fe_{0.3}O_{3-d}$	Tong, et al.	2003
CLFC	$Ca_{0.6}La_{0.4}Fe_{0.75}Co_{0.25}O_{3-d}$	Diethelm, et al.	2003
LCF	$La_{0.4}Ca_{0.6}FeO_{3-d}$	Diethelm, et al.	2003
LCFC	$La_{0.6}Ca_{0.4}Fe_{0.75}Co_{0.25}O_{3-d}$	Diethelm, et al.	2004
LSC	$La_{0.5}Sr_{0.5}CoO_{3-d}$	Van der Haar	2001
LSCF	$La_{0.6}Sr_{0.4}Co_{0.2}Fe_{0.8}O_{3-d}$	Shao	2003
LSGF	$La_{0.15}Sr_{0.85}Ga_{0.3}Fe_{0.7}O_{3-d}$	Shao	2003
LSGF-BSCF	$12.8La_{0.15}Sr_{0.85}Ga_{0.3}Fe_{0.7}O_{3-d}$ $Ba_{0.5}Sr_{0.5}Fe_{0.2}Co_{0.8}Fe_{0.2}O_{3-d}$	Wang, et al.	2003

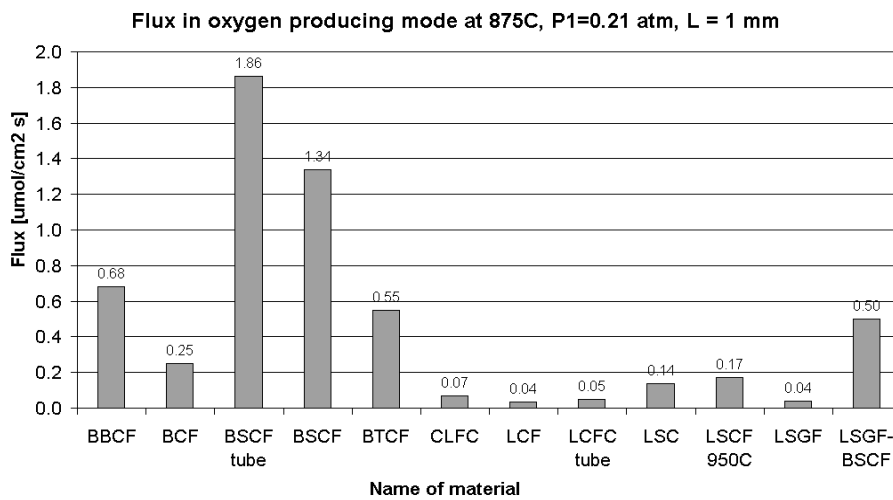

Figure 18. Normalised flux for the various materials (Foy and McGovern, 2005).  
 $\mu\text{mol} = \mu\text{mol}$

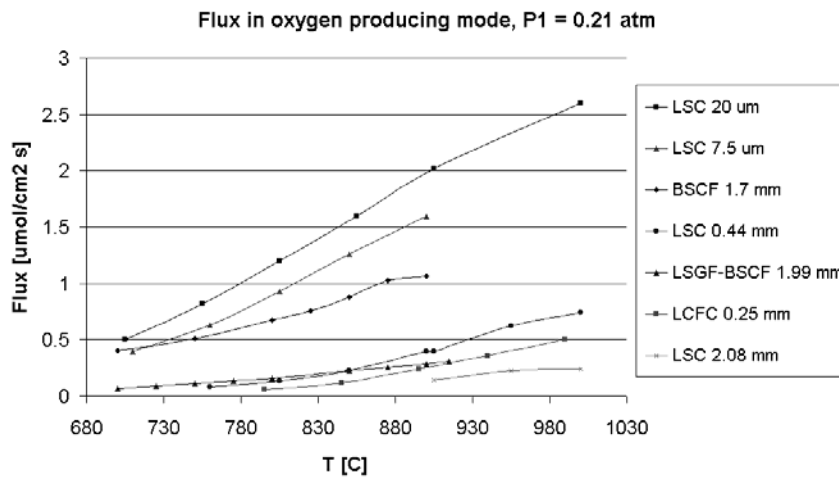

Figure 19. Actual non-normalised fluxes for membranes with different physical thicknesses. The names are listed in order of decreasing flux. (Foy and McGovern, 2005).  
 $\mu\text{mol} = \mu\text{mol}$

The reactor temperature is controlled by the temperature of combustion. The fragility of the materials under consideration means that the temperature of the combustion must be relatively low ( $<1250^{\circ}\text{C}$ ). Such a low temperature results in a relatively low efficiency. In addition to this, the AZEP group have identified staged combustion using partial catalytic oxidation as the optimum method of achieving low temperature complete combustion (Sundkvist and Eklund, 2004). This complicated method of combustion brings its own engineering challenges.

The ITM modules are based on an extruded ceramic structure shown in *Figure 21*. MCM, or mixed conducting membrane, is the ITM material.

The extruded ceramic is a porous support, which is coated with a dense membrane, as shown in *Figure 22*.

Further development of the AZEP reactor is reported by Selimovic (2005), and Sundkvist and Eklund (2004). These papers give comprehensive information on many aspects of the reactor

development. Many of the engineering challenges for the reactor are similar to those faced by heat exchanger designers, for example improving the surface to volume ratio. Dealing with non-uniform flow distribution is a headache for all designers of chemical and nuclear reactors, and the AZEP reactor is no exception. Selimovic (2005) gives detailed information on the various options under consideration for the solution of these problems. He identifies counterflow as more effective than coflow, which is in accordance with the heat exchanger theory, and also presents data on ITM materials. TABLE VIII shows comprehensive data on the reactor development. Note the oxygen partial pressure at the inlet is 20.7 kPa, implying that the inlet air is at atmospheric pressure. The operation pressure is defined as 10 bar, however Sundkvist and Eklund report that tests have shown that the system operates as expected to a pressure of 10 bar and a temperature of  $900^{\circ}\text{C}$  (2005).

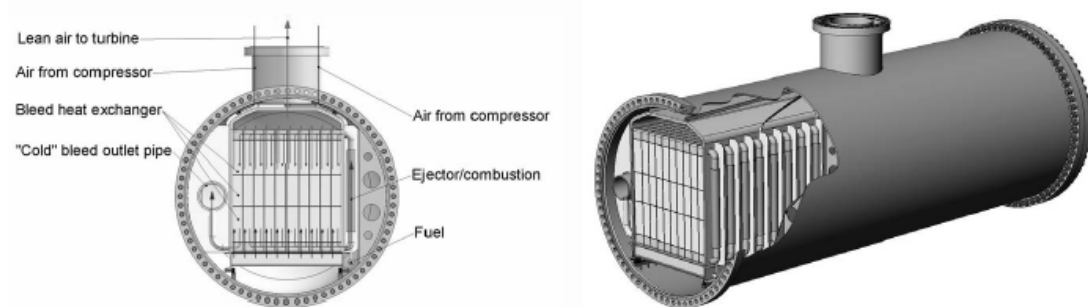

Figure 20. Design for an ITM reactor for the AZEP cycle (Sundkvist and Eklund, 2004).

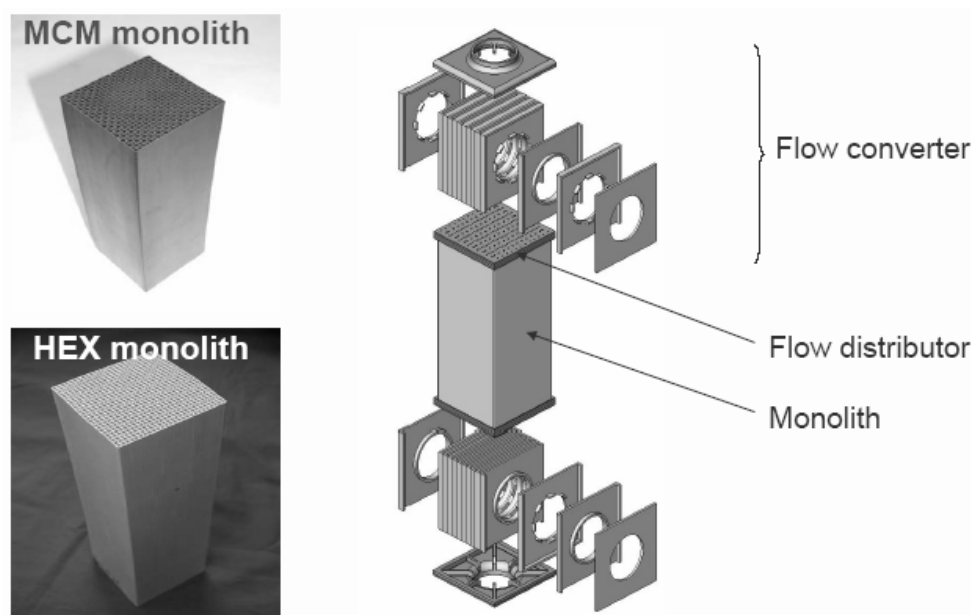

Figure 21. Design for an ITM reactor for the AZEP cycle (Sundkvist and Eklund, 2004).

In addition to the engineering challenges inherent in the design of the unit, the reactor also has high maintenance costs. It seems likely that the ceramic parts will have a life of 2.5 to 7.5 years (Sundkvist and Eklund, 2004).

Renz (2005) presents detailed information on the design of the membrane reactor for the oxycoal-AC cycle. Mechanical stability of the ceramic is again provided by using dense

membranes on porous supports. Two shapes are compared – tubular membranes with cross flow and planar membranes with counterflow, as shown in *Figures 23-24*. Detailed information on pressures and temperatures in the unit is presented, along with calculations showing stress in the ceramic. (Renz, 2005)

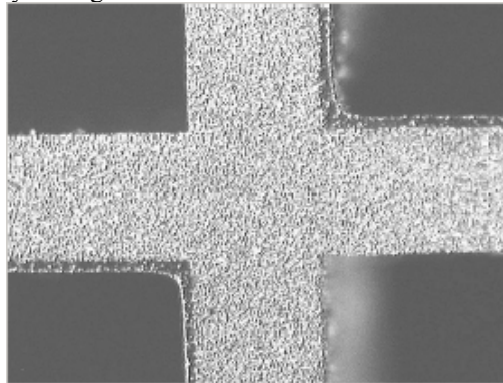

Figure 22. Porous support with dense membrane (Sundkvist and Eklund, 2004).

TABLE VIII. TECHNICAL DATA FOR AZEP REACTOR (SELIMOVIC, 2005).

Temperature of inlet air ( MCM)	700°C
Temperature of inlet sweep ( MCM)	1000°C
Operation pressure	10 bar
Oxygen partial pressure ( inlet air side)	20.7 kPa
Oxygen partial pressure ( inlet seep side)	0.8 kPa
Hydraulic diameter (square channel)	2 mm
Wall thickness	0.6 mm
MCM length	0.4 m
Number of repeating units	500
Porosity (porous support)	0.32
Tortuosity (porous support)	2.2

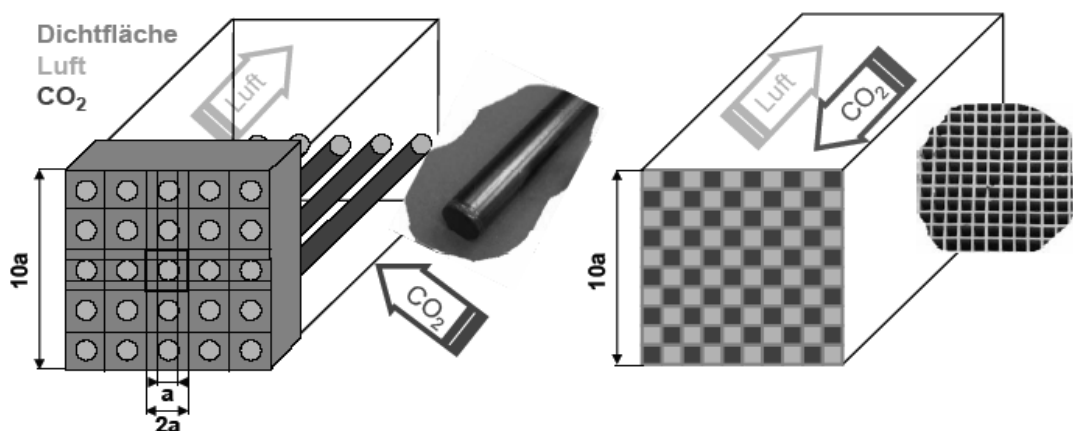

Figure 23. Possible structures for membrane reactor in the oxycoal-AC cycle (Renz et al., 2005).  
*Dichtflaeche* = sealing surface; *Luft* = air

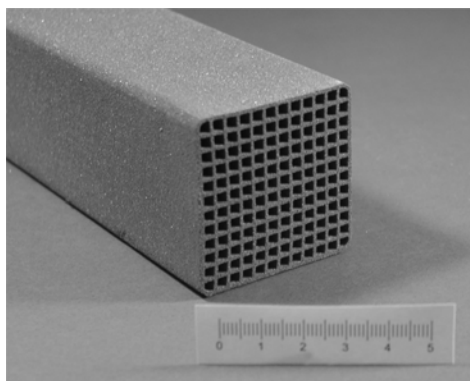

Figure 24. Membrane tested for oxycoal cycle (Renz, 2004).

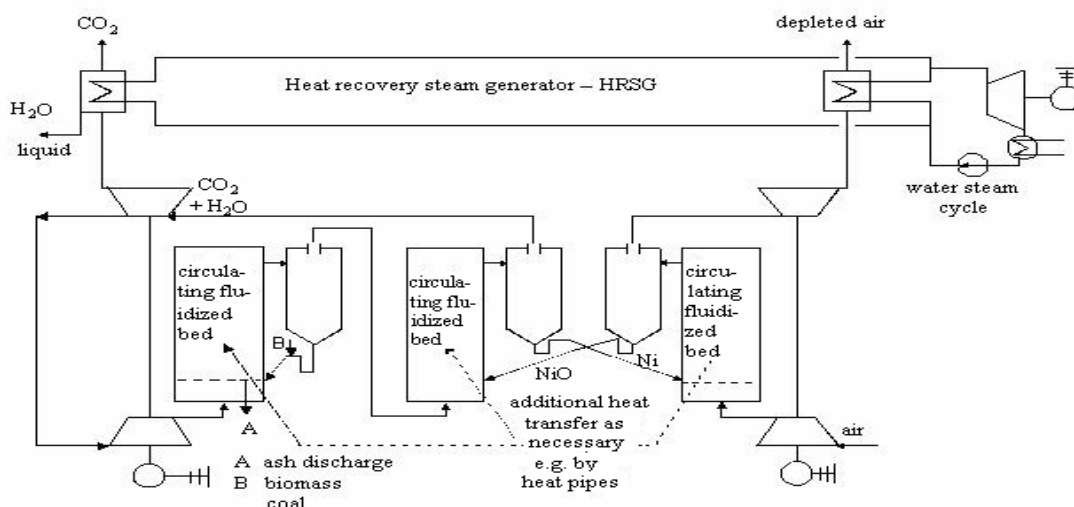

Figure 25. Coal or biomass fired zero emission cycle using metal as the oxygen carrier (Leithner, 2005).

## 5. Chemical Looping Combustion

Knoche and Richter (1968) proposed using metals as a carrier for oxygen to increase combustion efficiency. Metals would be oxidised using air, and the metal oxides would then be reduced by a fuel in a separate chamber. Although the aim of Knoche and Richter was to increase combustion efficiency, this method of combustion, now called chemical looping combustion, provides a means of zero emission combustion.

Ishida developed and experimentally proved this concept for zero emission (Ishida and Jin, 1998). A number of research groups are investigating chemical looping combustion, and it is currently at the laboratory scale. Leithner (2005) shows a schematic, reprinted here as Figure 25, for a coal or biomass fired cycle using nickel as the oxygen carrier.

Leithner notes that this concept is similar to that of oxygen transport using oxygen ion transport ceramics. He demonstrates this with a

similar schematic, using a membrane instead of the metal oxide subsystem, shown in Figure 26. This cycle concept is the same as the Milano cycle (Romano et al., 2005) or the oxycoal cycle (Renz et al., 2004). The use of ceramic membranes instead of metal oxides removes the need for two of the circulating fluidised bed reactors. Use of membranes is currently at a more advanced stage than chemical looping combustion. Whether the increase in combustion efficiency using chemical looping sufficiently compensates for the greater mechanical complexity of the cycle remains to be seen.

There is some commercial interest in chemical looping combustion. The US Department of Energy has granted funding to the BOC group, who are using flue gas recycling to burn coal in a mixture of oxygen and flue gas (Anna, 2005): "BOC plans to apply its CAR (Ceramic Autothermal Recovery) oxygen production process that uses the mineral perovskite to absorb oxygen and subsequently release it in a circulating fluidized bed".

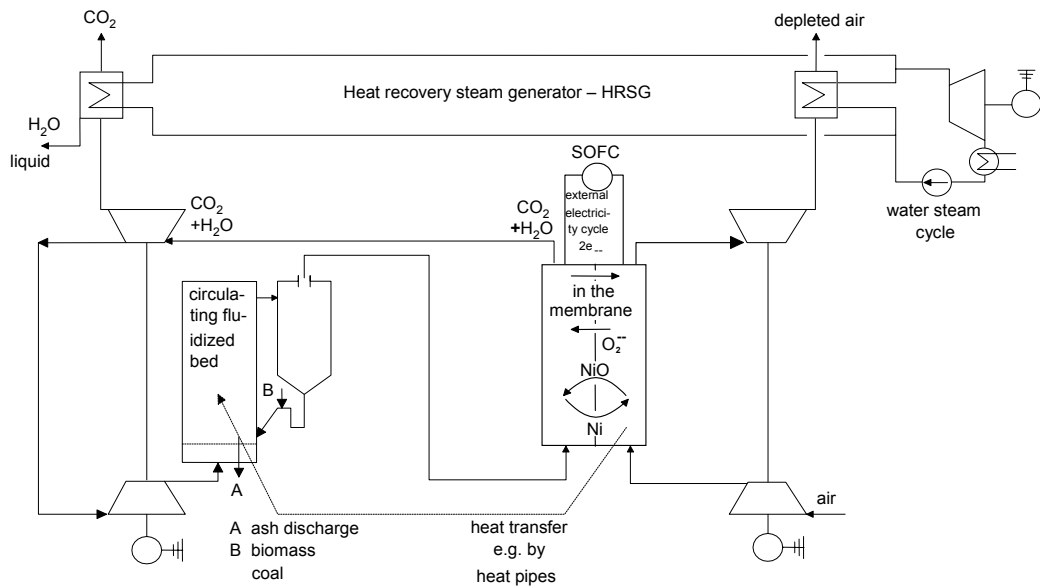

Figure 26. Coal or biomass fired zero emission cycle using an ion transport membrane as the oxygen carrier (Leithner, 2005).

Perovskite is an oxygen ion transport ceramic used in ion transport membranes, but it seems that BOC are using perovskite as the oxygen carrier in a chemical looping system. Use of ion transport ceramics instead of metal oxides in chemical looping is an interesting new development.

## 6. Conclusions

- The ion transport membrane reactors that are required for zero emission power plants are being developed successfully, bringing zero emission plants closer to realisation. Much work remains to be done, but when available, these reactors will enable the construction of zero emission plants without the loss in efficiency and increase in cost due to cryogenic oxygen production.
- The development of the ZENG cycle, including a nitrogen turbine, is at a stage that makes it impossible to state whether carbon dioxide or water vapour recirculation is the more efficient.
- A demonstration plant using carbon dioxide recirculation is required to evaluate its benefit.
- Use of oxygen carriers, such as in the Ceramic Autothermal Recovery system, may be a useful option for zero emission power production.
- Businesses are becoming interested in zero emission power plants, which indicates that ZEPPs will become a multibillion dollar industry. Carbon

taxes or emissions trading offer an opportunity to ensure economic viability of ZEPPs.

## Acknowledgements

We wish to thank the Program for Human Environment of Rockefeller University for the support of this work.

We acknowledge the support of the Irish Research Council through the Embark Initiative.

## Acronyms

AZEP	advanced zero emission power
BFW	boiler feed water
C	compressor
CAR	ceramic autothermal recovery
CC	combustion chamber
CC	CO <sub>2</sub> compressor
CES	clean energy systems
CHP	combined heat and power
COOPERATE	CO <sub>2</sub> prevented emission recuperative advanced turbine energy
CW	cooling water
EG	electric generator
EM	electric motor
EOR	enhanced oil recovery
ECBM	enhanced coal bed methane recovery
FBC	fluidised bed combustor
FT	fuel tank
HE	heat exchanger
HP	high pressure
HPT	high pressure turbine
HTT	high temperature turbine
HRSG	heat recovery steam generator

HX	heat exchanger
INJ	fuel injector
IP	intermediate pressure
IPT	intermediate pressure turbine
IGCC-Matiant	integrated gasification coal cycle matiant
ITM	ion transport membrane
ITMR	ion transport membrane reactor
L	luft (air)
LHV	lower heating value
LP	low pressure
LPT	low pressure turbine
Matiant	cycle designed by MATHieu and IANTovski
MCM	mixed conducting membrane
MHX	multi-heat-exchanger
NG	natural gas
OITM	oxygen ion transport membrane
P	pump
PE	piston engine
R	radiator
RG	rauchgas (exhaust gas)
RH	reheater
SOFC	solid oxide fuel cell
TC	air turbocompressor
TIT	turbine inlet temperature
WS	water separator
ZECA	zero emission coal alliance
ZEMPES	zero emission membrane piston engine system
ZENG	zero emission norwegian gas
ZEITMOP	zero emission ion transport membrane oxygen power
ZEPP	zero emission power plant

## References

- Akinfiyev N., McGovern J., Yantovski E., 2005, "Zero Emissions Power Generation with CO<sub>2</sub> Reduction by Fayalite," *Int. J. of Thermodynamics*, Vol. 8 (No. 3), pp. 155-157.
- Anderson R.E., Doyle S. E., Pronske K. L., 2004, "Demonstration and Commercialization of Zero-Emission Power Plants" *29th International Technical Conference on Coal Utilization & Fuel Systems*, April 18-22, Clearwater, FL, USA.
- Anna D., 2005, "DOE Advances Oxycombustion for Carbon Management", *DOE National Energy Technology Laboratory, web article*, [http://www.fe.doe.gov/news/techlines/2005/tl\\_oxycombustion\\_award.html](http://www.fe.doe.gov/news/techlines/2005/tl_oxycombustion_award.html) (Issued on November 17, 2005).
- Ausubel J., 2004, "Big green energy machines", *The Industrial Physicist*, Oct. / Nov. 2004, p.21.
- Beichel R., 1996, *US Patent 5,715,673*, filed 25 June 1996, issued 10 Feb. 1998.
- Berry G. F., Wolsky A. M., 1986, "Modelling heat transfer in an experimental coal-fired

furnace when CO<sub>2</sub>/O<sub>2</sub> mixture replace air", *WAM ASME*, Anaheim CA, Paper 86-WA/HT-51.

Bolland O., 2004a, "Power cycles with CO<sub>2</sub> capture," *NTNU, Tep9*,

[www.ept.ntnu.no/fag/tep9/inhold/CO2\\_tep9.pdf](http://www.ept.ntnu.no/fag/tep9/inhold/CO2_tep9.pdf)

Bolland O., 2004b, "CO<sub>2</sub> capture technologies - an overview," *The Second Trondheim Conference on CO<sub>2</sub> Capture, Transport and Storage*, 25-26 Oct., Trondheim, Norway.

Bolland O., Saether, 1992, "New concepts for natural gas fired power plants which simplify the recovery of carbon dioxide", *En. Conv. Mgmt*, Vol. 33, No. 5-8, pp. 467-475.

Bouwmeester H., Burggraaf A., 1996, "Dense Ceramic Membranes for Oxygen Separation", *Ch. 11 in the CRC Handbook of Solid state Electrochemistry*, CRC Press, Boca Raton.

Bredesen R., Jordal K., Bolland O., 2004, "High temperature membranes in power generation with CO<sub>2</sub> capture," [www.zero.no/fossil/CO2/200409121620/200409121627](http://www.zero.no/fossil/CO2/200409121620/200409121627)

CO<sub>2</sub> Norway, 2005, "Overview of the Phase-1 'Base Case' Configuration", *Description of ZENG Project on CO<sub>2</sub> Norway website*, updated 23/3/2005.

<http://www.co2.no/default.asp?UID=49&CID=36>

Degtiarev V. L., Grybovsky V. P., 1967, "Carbon dioxide semi-closed power plant", Author certif., *USSR No. 295 897* of July 28, 1967, published in *Bull. Inventions* No. 8, F01k13/00, Co1b 3/00, Nov. 12, 1971.

De Ruyck J., 1992, "Efficient CO<sub>2</sub> capture through a combined steam and CO<sub>2</sub> gas turbine cycle", *En. Conv. Mgmt.*, Vol. 33, No. 5-8, pp. 397-404.

Dyer P., Richards R., Russek S., Taylor D., 2000, "Ion transport membrane technology for oxygen separation and syngas production", *Solid State Ionics*, Vol. 134, pp. 21-33.

Foy K., McGovern J., 2005, "Comparison of Ion Transport Membranes", *Proc. 4<sup>th</sup> Annual Conference on Carbon Capture and Sequestration* May 2-5, Alexandria, VA, USA, Paper 111.

Göttlicher G., 1999, "Energetik der Kohlendioxidrückhaltung", *Reihe 6*, No. 421, VDI-Fortschrittberichte, Düsseldorf.

Göttlicher G., 2003, "Process Comparison," [http://eny.hut.fi/education/courses/Ene-47\\_200-2003/GHG2003Course\\_material/3-GG-1bIntroduction-overview-](http://eny.hut.fi/education/courses/Ene-47_200-2003/GHG2003Course_material/3-GG-1bIntroduction-overview-)

Gupta M., Coyle I., Thambimuthu K., 2003, "CO<sub>2</sub> capture technologies and opportunities in

- Canada”, *1<sup>st</sup> Canadian CC&S Technology Workshop*, Calgary, Canada.
- Heitmeir F., Sanz W., Göttlich, E., Jericha H., 2003, "The Graz Cycle – A Zero Emission Power Plant of Highest Efficiency", XXXV Kraftwerkstechnisches Kolloquium, Dresden, Germany.
- Hochstein D. P., 1940, "Carbon dioxide power cycle", *Soviet Boiler and Turbine Construction*, No. 10, pp. 420-423.
- Hoffman A., Feher B., 1971, "150 kWe Supercritical Closed Cycle System", *Trans. ASME*, Ser. A, No. 1.
- Holt T., Lindeberg E., 1992, "Thermal power-without greenhouse gases and with improved oil recovery," *En. Conv. Mgmt.*, Vol. 33, No. 5-8, pp. 595-602.
- International Energy Agency Working Party on Fossil Fuels, 2002, "Technology Status Report: Zero Emission Technologies for Fossil Fuels", <http://www.cslforum.org/documents/TSRMay2002.pdf> (accessed on 9/12/05).
- Ishida M., Jin H., 1998, "Greenhouse gas control by a novel combustion: no separation equipment and energy penalty," *4<sup>th</sup> Int. Cong. GHGT*, Ingterlaken, ENT-13.
- Jericha H., 1985, "Efficient Steam Cycles with Internal Combustion of Hydrogen and Stoichiometric Oxygen for Turbines and Piston Engines", *CIMAC conference paper*, Oslo, Norway.
- Jericha H., Sanz W., Woisetschläger J, Fesharaki M., 1995, "CO<sub>2</sub> - Retention Capability of CH<sub>4</sub>/O<sub>2</sub> – Fired Graz Cycle", *CIMAC Conference Paper*, Interlaken, Switzerland
- Jericha H., Lukasser A., Gatterbauer W., 2000, "Der "Graz Cycle" für Industriekraftwerke gefeuert mit Brenngasen aus Kohle- und Schwerölvergasung" (in German), VDI Berichte 1566, *VDI Conference Essen*, Germany
- Jericha H., Göttlich E., Sanz W., Heitmeir F., 2003, "Design Optimisation of the Graz Cycle Prototype Plant", ASME Paper 2003-GT-38120, ASME Turbo Expo 2003, Atlanta, USA, *ASME Journal of Engineering for Gas Turbines and Power*, Oct. 2004, Vol. 126, pp. 733-740.
- Keller C., Strub R., 1968, "The gas turbine for nuclear power reactors", *VII World Energy Congress*, Moscow, Paper 167.
- Knoche K. F., Richter H., 1968, "Verbesserung der Reversibilitaet von Verbrennungsprocesen", *BWK*, No. 5, May, pp. 205-210.
- Leithner R., 2005, "Energy conversion processes with intrinsic CO<sub>2</sub> separation," *Transactions of the Society for Mining, Metallurgy and Exploration*, Vol. 318, pp. 161-165.
- Levin L., Nesterovski I., Yantovski E., 2003, "Zero emission Rankine cycle with separate ion transport membrane combustor," *7<sup>th</sup> Int. Conf. for a Clean Environment*, 7-10 July, Lisbon, Portugal.
- Lorentzen G., Pettersen J., 1990, "Power process development for northern climate," *Eurogas'90. Proc. of the Conf. on Natural Gas*, May 28-30, Trondheim, pp. 451-462.
- Marchetti C., 1979, "Constructive solutions to the CO<sub>2</sub> problem", in *Man's Impact on Climate*, Elsevier, New York.
- Marin O., Bourhis Y., Perrin N., Di Zanno P., Viteri F., Anderson R., 2005, "High Efficiency, Zero Emission Power Generation Based on a High-Temperature Steam Cycle," [http://www.cleanenergysystems.com/2005/media/kit/AL\\_CESClearwaterPaper.pdf](http://www.cleanenergysystems.com/2005/media/kit/AL_CESClearwaterPaper.pdf) (cessed 9/12/05).
- Mathieu P., 1994, "The Use of CO<sub>2</sub> Gas Turbines," *Power-Gen Europe '94 Conf.*, Cologne, Germany.
- Mathieu P., 1998, "Presentation of an innovative Zero-Emission cycle for mitigation the global climate change", *Int. Journ. of Applied Thermodyn.*, Vol. 1, No.1-4.
- Mathieu P., Dubuisson R., Houyou S., Nihart R., 1999, "Combination of near zero emission power cycles and CO<sub>2</sub> sequestration", *Fifth International Conference on Technologies and Combustion for a Clean Environment*, July, Lisbon.
- Mathieu P., Desmaret F., 2001, "Integration of a high temperature fuel cell (SOFC) in a near zero CO<sub>2</sub> emission power cycle", *ECOS 2001*, May, Istanbul, Turkey.
- Mathieu P., van Loo F., 2005, "Modeling of an IGCC Plant based on oxy-fuel combustion combined cycle", *Proc. ECOS 2005*, June 20-22, Trondheim, Norway.
- Nakayama S. et al., 1992, "Pulverized coal combustion in O<sub>2</sub>/CO<sub>2</sub> mixture on a power plant for CO<sub>2</sub> recovery", *Energy Conv. Mgmt.*, Vol. 33, No. 5-8, pp. 379-386.
- Pak P. S., Nakamura K., Suzuki Y., 1989, "Closed dual fluid gas turbine power plant without emission of CO<sub>2</sub> into the atmosphere", *IFAC/IFORS/IAEE Int. Symp. on Energy Systems Management and Economics*, Oct. 1989, pp. 249-254., US Pat. 5,247,791, Sept. 28, 1993.
- Pechtl P., 1991, "CO<sub>2</sub> emissionsminderung“, *Erdol und Kohle Petrochemie*, H. 4, Apr., pp. 159-162.

- Pham A. Q., 1997, "Making Liquid Fuels From Natural Gas", [www.vacets.org/vtic97/qapham.html](http://www.vacets.org/vtic97/qapham.html)
- Renz U., 2004, "Entwicklung eines CO<sub>2</sub>-emissionsfreien Kohleverbrennungs-processes zur Stromerzeugung in einem Verbundvorhaben der RWTH Aachen", *XXXVI. Kraftwerkstechnisches Kolloquium: Entwicklungspotentiale fuer Kraftwerke mit fossile Brennstoffen*, 19-20 Oct., Dresden.
- Renz U., Kneer R., Abel D., Niehuis R., Maier H., Modigell M., Peters N., 2005, "Entwicklung eines CO<sub>2</sub>-emissionsfreien Kohleverbrennungs-processes zur Stromerzeugung", *CCS-Tagung Juelich*, Nov. 10-11, RWTH Aachen.
- Romano M., Napoletano S., Chiesa P., Consonni S., 2005, "Decarbonized Electricity Production from Coal by means of Oxygen Transport Membranes", *4<sup>th</sup> Annual Conference on Carbon Sequestration*, May 2-5, Alexandria VA, p. 1402.
- Ruether J., Le P., White C., 2000, "A Zero-CO<sub>2</sub> Emission Power Cycle Using Coal", *Technology*, Vol. 7S, pp. 95-101.
- Sanz W., Jericha H., Moser M., Heitmeir F., 2004, "Thermodynamic and Economic Investigation of an Improved Graz Cycle Power Plant for CO<sub>2</sub> Capture", ASME Paper GT2004-53722, ASME Turbo Expo 2004, Vienna, Austria.
- Sanz W., Jericha H., Luckel F., Göttlich E., Heitmeir F., 2005, "A Further Step Towards a Graz Cycle Power Plant for CO<sub>2</sub> Capture", ASME Paper GT2005-68456, *ASME Turbo Expo 2005*, Reno-Tahoe, Nevada, USA.
- Selimovic F., 2005, "Modelling of Transport Phenomena in Monolithic Structures related to CO<sub>2</sub>-free power process", Lund Univ. of Technology, Sweden, 03.07.2005.
- Shockling L., Huang K., Christie G., 2001, "Zero Emission Power Plants Using Solid Oxide Fuel cell and Oxygen transport Membranes", *Vision 21 Program Review meeting*, Nov. 6, US DOE, NETL.
- Steinberg M., 1981, "A carbon dioxide power plant for total emission control and enhanced oil recovery", *BNL*, 30046, August.
- Steinberg M., 1992, "History of CO<sub>2</sub> greenhouse gas mitigation technologies", *Energy Conv. Mgmt.*, Vol. 33, No. 5-8, pp. 311-315.
- Sundqvist S., Griffin T., Thorshaug N., 2001, "AZEP-Development of an Integrated Air Separation Membrane-Gas Turbine," *Second Nordic Minisymposium on CO<sub>2</sub> capture*, Oct. 26, Chalmers Univ., Göteborg.
- Sundqvist S., Klang A., Sjödin M., Wilhelmsen K., Asen K., Tintinelli A., McCahey S., Ye H., 2004, "AZEP gas turbine combined cycle power plants", *GHGT-7*, Uni Regina, Canada, <http://uregina.ca/ghgt7/PGF/papers/peer/079.pdf>
- Sunquist S., Eklund H., Griffin T., 2004, "AZEP – an EC-funded Project for Development of a CCGT Power Plant without CO<sub>2</sub> Emissions", *CAME-GT 2nd Int'l Conference on Gas Turbine Technologies*, Bled, Slovenia, <http://www.came-gt.com/2InternatConf/Tech%20Session%203/SGSundkvist.pdf>
- Tomski, 2003, "Zero Emission Technologies for Fossil Fuels Technology Status Report. Appendix I: R&D Visions (Request for Project Updates)," Preliminary Draft Update: June 2003, <http://www.cslforum.org/documents/TSRAppendix2003.pdf> (Accessed on 9/12/05).
- van der Haar M., 2001, "Mixed-conducting perovskite membranes for oxygen separation," *PhD thesis*, Univ. of Twente, Enschede.
- Van Steenderen P., 1992, "Carbon dioxide recovery from coal and natural gas fired combined cycle power plants by combustion in pure oxygen and recycled carbon dioxide", *COMPRIMO Consulting Services BV*, Amsterdam.
- VGB, 2005, "CO<sub>2</sub> Capture and Storage. VGB Report on State of the Art," VGB Power Tech Service GmbH, Essen, 25<sup>th</sup> August.
- Wall G., Yantovski E., Lindquist L., Tryggstad J., 1995, "A zero emission combustion power plant for enhanced oil recovery", *Energy – The Int. Journ.*, Vol. 20, No. 8, pp. 823-828.
- Wolsky A., 1985, "A new approach to CO<sub>2</sub> recovery from combustion", *Proc. of a workshop: "Recovering Carbon Dioxide from Man-Made Sources"*, Feb. 11-13, Pacific Grove, CA, Report ANL/CNSV-TM-166, pp. 76-81.
- Yantovski E., 1991, "The thermodynamics of fuel-fired power plants without exhaust gases", *World Clean Energy Conf. CMDC*, 4-7 Nov, Geneva, pp. 571-595.
- Yantovski E., Zvagolski K., Gavrilenko V., 1992, "Computer exergonomics of power plants without exhaust gases", *En. Conv. Mgmt.*, Vol. 33, No. 5-8, pp. 405-412.
- Yantovski E., Degtiarev V. L., 1993, "Internal combustion carbon dioxide power cycles without exhaust gases", *Int. Conf. ENSEC '93*, July 5-9, Cracow, Poland, pp. 595-602.
- Yantovski E., Wall G., Lindquist L., Tryggstad J., Maksutov R., 1993, "Oil Enhancement Carbon Dioxide Oxygen Power Universal Supply (OCDOPUS project)", *En. Conv. Mgmt.*, Vol. 34, No. 9-11, pp. 1219-1227.
- Yantovski E., Wall G., Lindquist L., Tryggstad J., 1994a, "Exergonomics of an EOR (Ocdopus)

project”, *Energy – The Int. Journ.*, Vol. 19, No. 12, pp. 1275-1278.

Yantovski E., Zvagolsky K., Gavrilenko V., 1994b, “The COOPERATE power cycle”, *Proc. WAM ASME, AES*, Vol. 33, pp. 105-112.

Yantovski E., 1994c, “Energy and Exergy Currents”, *NOVA Sci.*, NY

Yantovski E., 1996, “Stack downward. zero emission fuel-fired power plant concept”. *En. Conv. Mgmt.*, Vol. 37, No. 6-8, pp. 867-877.

Yantovski E., Kushnirov V., 2000b, “The Convergence of Oil and Power on Zero Emission Basis”, *OILGAS European Magazine* 2/2000.

Yantovski E., 2000c, “Gas Power Zero Emission Convergency Complex”, *OILGAS European Magazine*, 4/2000.

Yantovski E., Gorski J., Smyth B., ten Elshof J. E., 2002, “ZEITMOP Cycle (Zero Emission Ion Transport Membrane Oxygen Power)”, *Proc. Int. Conf. ECOS 2002*, July 3-5, Berlin, pp. 1153-1160.

Yantovski E., Gorski J., Smyth B., ten Elshof J., 2003a, “Zero Emission Fuel-fired Power plant with Ion Transport Membrane”, *2<sup>nd</sup> Annual Conf. on Carbon Sequestration*, May 5-8, Alexandria, VA, USA.

Yantovski E., Shokotov M., 2003b, “ZEMPES (Zero Emission Piston Engine System), *2<sup>nd</sup> Annual Conf. on Carbon Dioxide Sequestration*, May 5-8, Alexandria, VA, USA.

Yantovski E., Shokotov M., McGovern J., Vaddella V., 2004, “Zero emission membrane piston engine system (ZEMPES) for a bus”, *Proc. VAFSEP 2004*, [www.netl.doe.gov/publications/proceedings/01/vision21/v211-5.pdf](http://www.netl.doe.gov/publications/proceedings/01/vision21/v211-5.pdf)

Yantovski E., Shokotov M., McGovern J., Shokotov V., Foy K., 2005, “Elaboration of Zero Emission Membrane Piston Engine System (ZEMPES) for propane fuelling,” *4<sup>th</sup> Carbon Sequestration Conference* May 2-5, Alexandria VA USA, Paper 109.